

INSTALLATION, USE AND MAINTENANCE MANUAL

DIESEL GENERATOR SETS

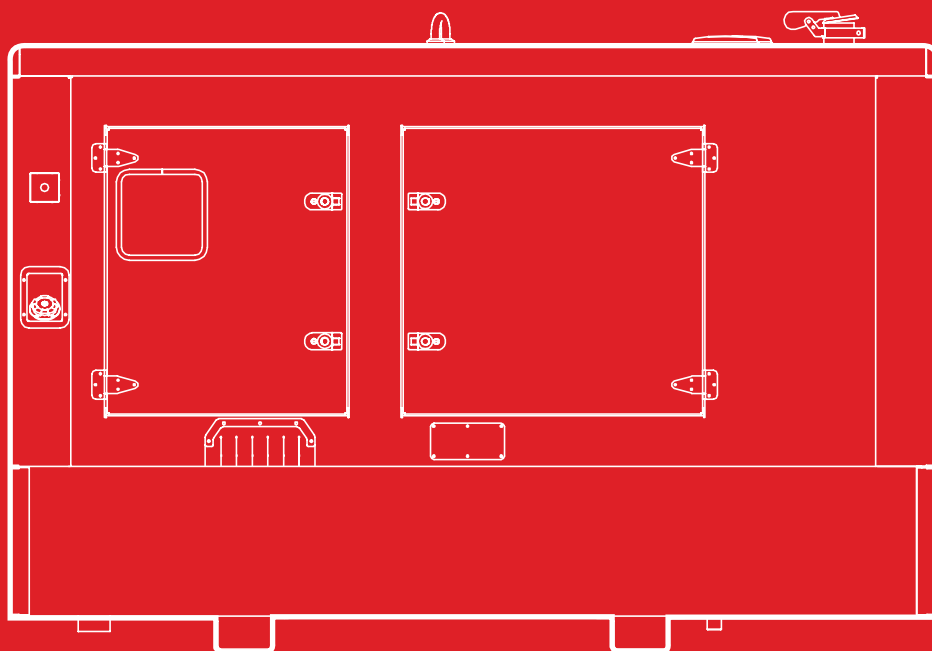

HIMOINSA
A **YANMAR** COMPANY

INDEX

- 3** 1. Introduction
- 4** 2. Safety standards
- 14** 3. General Description
- 18** 4. Unloading, handling and transportation
- 23** 5. Mobile generator sets
- 27** 6. Operating conditions
- 33** 7. Installation
- 51** 8. Using the generator set
- 65** 9. Maintenance
- 66** 10. Warranty
- 69** 11. Appendix I: Equivalence of the different units with SI units

1. INTRODUCTION

This manual aims to provide the information and basic instructions for proper installation, transport, maintenance and use of your generator set.

It is essential that all the safety rules and warnings are read carefully before, during and after the generator set has been put into operation, only in this way can we ensure optimum, regular service under perfect conditions of reliability and safety.

This a general document used for a wide range of products with a variety of optional features. It is possible that there are components, instructions or safety standards mentioned in this manual which are not applicable or are insufficient for the specific genset that has been acquired. In this case you must evaluate and determine which instructions are valid for your genset, supplementing them if necessary. Consult the HIMOINSA Technical Department in the event of any doubts.

HIMOINSA S.L. considers it necessary to highlight that the validity of the information described in this manual may depend on the date it was issued, since aspects such as technological advances and updates to the regulations in force, require us to implement modifications without notice.

This manual and the other reference documents, form an integral part of the generator set which has been acquired and must be preserved and protected against any agents that could damage them. This documentation should accompany the equipment when it is transferred to another user or to a new owner.

The manual must always be kept nearby for reference purposes in case of doubt. Although the information in this manual has been verified in detail, HIMOINSA waives any liability due to any calligraphic, typographical or transcription errors.

In accordance with European Directives concerning the Protection of Consumers and Users, HIMOINSA is excluded from any liability resulting from the defective installation and/or the improper use of the machine or from failure to comply with the rules contained in this manual.

2. SAFETY STANDARDS

Before working on the machine it is important to carefully read the safety standards indicated, and find out about any local requirements in terms of safety.

Installation, operation, maintenance and repairs must only be carried out by authorized and competent personnel, with the owner of the generator set responsible for ensuring these operations are conducted safely. Parts and accessories must be replaced if they are not in safe operating conditions.

Taking the contents of this manual as our premise, detailed below are the basic criteria for the safety of the reader and that of others, which should be carefully followed.

2.1 GENERAL SAFETY PRECAUTIONS

For your own safety and that of others, pay particular attention to the following basic safety criteria:

- Do not allow unauthorized persons to access the generator set or people with pacemakers, due to possible electromagnetic interference on cardiac stimulation devices.
- Do not approach the generator set while wearing loose clothing or objects that may be attracted by the flow of air or the genset's moving parts.
- Do not smoke or cause sparks near the generator set or the external fuel installation.
- Exercise extreme caution with exhaust gases because depending on the fuel used these gases may contain carbon monoxide, a colourless, odourless gas which is very dangerous and harmful if inhaled.
- It is prohibited to by-pass and/or remove the safety devices as well as modify the settings of the generator set.
- It is forbidden to lean on the generator set or leave objects on it.

In the case of gensets which are automatically operated, it is also recommended to:

- Place a red light in a visible position and turn it on when the genset is running.
- Place a warning sign indicating the possibility of the machine unexpected starting automatically.
- Place an obligation sign indicating that “All maintenance operations must be performed with the genset in the LOCKED position”.
- To perform an emergency stop of the genset, press the “emergency stop” button located on the outer sides of the genset or internally or adjacent to the protection and control panel, depending on the genset.

NOTE:

In order to locate the place in which some of the components listed below are installed, go to Section 3.1 Composition of the generator set.

2.2 SAFETY DURING RECEIPT, STORAGE AND UNPACKING

- Upon receipt of the generator set check that the material received corresponds to the delivery order, and that the merchandise is in perfect condition.
- When lifting and transporting the genset, lifting devices with sufficient capacity must be used, following the instructions in Section 4.2 Unloading and Handling and Section 4.3 Transportation. All loose or pivoting parts must be securely fastened before lifting the equipment.
- When moving the generator set, and especially during elevation, we recommend using the points indicated specifically for these functions, having previously checked the optimal condition of said lifting points.

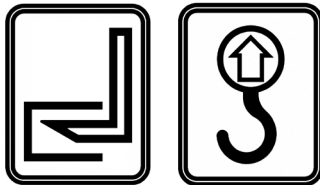

- It is strictly forbidden to use other lifting points, located on the engine, alternator or any other components.
- If the generator set is damaged for any reason during transport, storage, and/or assembly, it should not be put into operation without being checked first by our specialized staff.
- If you wish to store the genset until it is needed, it is advisable to use premises which are duly protected from chemical agents that can damage the machine's components.
- Unpacking should be carried out with care, avoiding any damage to the materials during the operation, especially when using levers, saws or other metallic tools.

2.2.1. RECOMMENDATIONS FOR STORING A HIMOINSA GENERATOR SET FOR PERIODS OF MORE THAN 12 MONTHS AND SUBSEQUENT START-UP

When a generator set is required to be stored for a period of more than twelve months, it is necessary to follow specific guidelines to prevent the premature deterioration of the different components.

Generator sets should be stored in a dry, covered place away from inclement weather and sudden changes in temperature.

NOTE

For procedures involving the engine, check the specific requirements of each engine manufacturer as described in its corresponding Operating and Maintenance manual.

Some important points to keep in mind are listed below:

PREPARING THE ENGINE FOR LONG PERIODS OF INACTIVITY

In order to prevent oxidation of internal engine parts and some injection system components, it is necessary to prepare the engine as indicated below whenever there will be a period of inactivity lasting more than twelve months:

1. Warm up the engine and empty the lubricating oil in the crankcase.
2. Fill the engine with protective oil to the dipstick “minimum” level. Start the engine and keep it running for about 5 minutes.
3. Drain the fuel from the injection circuit, the filter and the injection pump pipes.

4. Connect the fuel circuit to a reservoir filled with protective fluid and introduce the pressurised fluid into the circuit. After deactivating the injection system, crank the engine for about 2 minutes. This operation can be carried out by using a cable to polarise terminal 50 of the electric starter with a positive voltage equivalent to the nominal installation voltage.
5. Spray – g (10 g per litre piston displacement) of protective oil on the turbocharger inlet while the engine is cranking, as set out in the previous step.
6. Close all intake, drainage, aeration and exhaust openings with plugs or insulating tape.
7. Drain any residual protective oil in the crankcase.
8. Place signs displaying the message “NO OIL IN ENGINE” on the engine and control panel.
9. Drain the coolant, and place a “NO ANTI-FREEZE IN ENGINE” warning sign
10. Slacken the fan belts in the engine.
11. Dismantle the batteries and store them in a dry place with no sudden changes in temperature; keep them charged.

In case of long periods of inactivity, the described operations will need to be repeated every 12 months, following the sequence described above.

If it is wished to protect the external parts of the engine (for example, the flywheel, pulleys, etc.) they should be sprayed with protective oil, while avoiding the belts, connection cables or electrical equipment.

PRECAUTIONS TO BE TAKEN WITH THE ALTERNATOR

Keep in a dry place with no sudden changes in temperature.

Rotate through 90 degrees periodically to avoid bearing deformation.

STARTING THE ENGINE AFTER A LONG PERIOD OF INACTIVITY

1. Drain the residual protective oil from the crankcase.
2. Fill the engine with a specific lubricating oil, as indicated in the MAINTENANCE SUPPLIES table of each engine manufacturer’s specific Operating and Maintenance Manual.
3. Drain the protective fluid from the fuel circuit as indicated in step 3 of PREPARING THE ENGINE FOR LONG PERIODS OF INACTIVITY.

4. Remove the plugs and/or the adhesive tape from the engine’s intake, drainage, aeration and exhaust vents and restore the usage conditions. Connect the turbocharger intake manifold to the air filter.
5. Connect the fuel circuits to the tank in the generator set and complete the procedures indicated in step 4 of the section PREPARING THE ENGINE FOR LONG PERIODS OF INACTIVITY. During filling, the tank’s fuel return pipe must be connected to a container to prevent any residual protective liquid from entering the tank in the generator set.
6. Refill and maintain the engine coolant level as described above. Purge the circuit if necessary.
7. Start the engine and keep it running until the minimum RPM stabilises.
8. Check that the values indicated by the instruments on the control panel(s) are correct and there are no alarms activated.
9. Stop the engine.
10. Remove the NO OIL IN ENGINE signs from the engine and the control panel.

If the procedures described above have not previously been performed and the generator set has been stored for more than 12 months, the following operations must be carried out:

OPERATIONS TO BE PERFORMED ON THE ENGINE

1. Drain the engine oil and replace it with oil as indicated in each engine manufacturer’s specific Operating and Maintenance Manual.
2. Drain the antifreeze from the radiator and engine.
3. Remove all injectors and check their operating pressures.
4. Drain all fuel from the tank and check the cleanliness of the tank. Clean if necessary.
5. Introduce around 10 grams of engine oil through the injector holes.
6. Crank the engine in order to clean and lubricate the walls of the cylinders.
7. If the engine cranks freely, install the injectors.
8. Refill antifreeze and oil to specified levels.
9. Replace the oil, fuel and air filters.
10. Replace the accessory belt.

11. Refuel and purge the injection system.
12. Start the engine. (Before starting the engine, check that the power generator is in the NO GENERATION state: disconnect the AVR to do this).
13. Let the engine run for at least 30 minutes. In cases where it runs incorrectly, take the appropriate measures.
14. After running for approximately 50 h, replace oil and filter.

OPERATIONS TO BE PERFORMED ON THE GENERATOR

1. Turn the alternator to check for rubbing or seizure.
2. Check the insulation of the windings. Where insulation is low, carry out drying operations as described in the corresponding Operation and Maintenance Manual.
3. Check and, if necessary, tighten the generator's couplings and internal connections.
4. Start the generator set and verify that all nominal values are within the operating limits. In cases where it runs incorrectly, take the appropriate measures.
5. Check all control, security and alarm systems work correctly.

NOTE

All these operations must be carried out by qualified technical personnel.

2.3 SAFETY DURING INSTALLATION AND COMMISSIONING

- Installing the Generator Set and its accessories must be performed by qualified personnel. In the event of any difficulty during installation, consult HIMOINSA's Technical Department.
- It is important to know the emergency procedures related to the installation to be carried out, as well as positioning a fire extinguisher near the generator set. Consult the fire department for more information related to fire prevention.
- Always wear a protective helmet, safety shoes and gloves, protective goggles and dry, tight clothes.
- Do not modify the original protection devices, located on all the exposed rotary parts, hot surfaces, air intakes, belts and live parts.

- Do not leave disassembled parts, tools or any other accessories on the engine, nearby or in premises of the generator set.
- Never leave flammable liquids or rags soaked with flammable liquids near the genset, near electrical appliances or electrical installation parts (including lamps).
- Take all possible precautions to avoid risk of electrocution; connect to earth some of the points provided on the generator set and its accessories, ensuring this earthing is carried out in compliance with the relevant legislation. For more information, go to Section 7.1.7 General information. Earthing.
- Place a sign stating "IT IS PROHIBITED TO PERFORM OPERATIONS" on all insulation devices that isolate parts of the installation on which work must be carried out.
- Install the necessary safety protection devices on the parts that complete the installation.
- Insulate all the connections and disconnected wires. Do not leave the generator set's power terminals uncovered.
- Check and make sure the electrical connections for power and the auxiliary services are properly executed.
- Make sure that the power cables are installed in compliance with the requirements of all corresponding regulations, as the use of unsuitable cables may result in serious damage to both the equipment and people due to the hazardous electrical conditions.
- Check that the cyclic direction of the phases matches that of the network.
- Locate the position of the emergency stop buttons, the fast interceptor fuel valves, switches and any other possible emergency systems on the installation.
- Check the perfect operation of the genset's stop devices. In particular the following devices (if provided as standard): stop due to overspeeding, low oil pressure, high engine water temperature and the emergency stop button installed by the user, in general outside the premises.
- Ensure that all exhaust fumes are expelled correctly into the atmosphere and from a safe position away from doors, windows and air inlets.
- Change the exhaust system caps, in the event of receiving a genset with flat caps, and install tilting caps. For more information, go to Section 7.1.7 General information. Exhaust system.
- Check that the pipes and silencers are installed properly, that they have expansion joints and are protected against accidental impacts.

- Inspect for leaks in the fuel and oil pipes.
- In the event your genset is supplied with an engine coolant heater, connect it to the network via the incorporated plug, as this will allow faster cold starts to be performed.
- Locate sources of danger, for example leakage of fuel, lubricating oil, acid solutions, condensate drip, high pressures and other hazards.
- Before putting the machine into operation, make sure the generator set is provided with the right amount of lubricating oil, coolant and fuel.
- Identify the position of fire extinguishers and other safety and emergency devices and learn how to operate them.
- Check the genset is clean, as well as ensuring the surrounding area and escape routes are clean and unobstructed. Check for blockages in the openings as well as the inlet and outlet conduits.
- Check if there are staff working on other equipment in the area and if such work is dangerous and affects the operation of the installation.
- In the case of installations under environmental or operating conditions which are different to those for which the genset was designed, which can be found in the data sheet or on the identification plate of the genset, go to Section 6.3 Derating for operating environmental conditions to consider the possible correction factors to be applied.

2.4 SAFETY DURING OPERATION

- Do not allow access to the operating area of the generator set by persons who are unfamiliar with the safety conditions, children or animals.
- The person in charge of generator set operations and functioning must remain alert and ready to respond to and interpret a situation appropriately, and never work while physically or mentally fatigued or under the influence of medication, drugs or alcohol.
- It is advisable to have a minimum of two people present during operations that may pose a health risk, especially due to electrical hazards.
- Do not touch the generator set, especially cables, copper terminals and alternator connections, while the genset is running, as they are live. In the case of an electrical discharge, the first thing to do is stop the genset. If this is not possible, try to free the victim from the source of electrical energy using a non-conductive element. If the victim is partially or totally unconscious, perform cardiopulmonary resuscitation (CPR) and seek medical attention immediately.

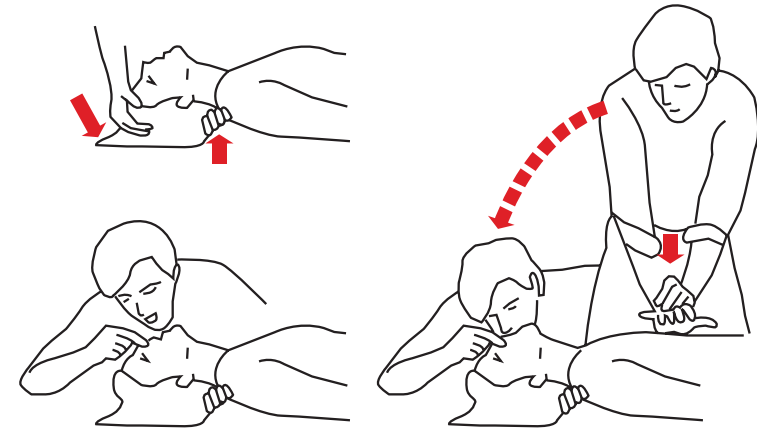

- Do not touch moving parts until the generator set has completely stopped.
- Check the fuel level in the tank, always ensuring it is at the necessary level for the use which will be given to the generator set.
- Never connect loads which are above the power range of the generator set.
- The lines of the anticipated loads to which the generated power will be supplied will always be connected to the genset before commissioning.
- Do not operate the genset if the air filter is not installed.
- Do not supply power to the battery charger if the batteries are not properly connected; the electronic devices could be damaged irreparably. Never disconnect the batteries while the engine is running.
- Stop the generator set immediately if any kind of abnormal operation is detected, such as excessive vibration, leaks, smoke or loss of output power.
- Keep doors of the canopy closed, in the case of soundproof gensets, when they do not need to be open, since the cooling system is designed for the genset to operate with all doors closed.
- The exhaust fumes produced by the generator set are dangerous to health; inhalation can be very harmful due to the concentration of carbon monoxide. Check that all exhaust fumes are discharged correctly and that the genset is properly ventilated.
- Maintain adequate ventilation to ensure your generator set functions properly. A lack of proper ventilation could cause injury or damage to property due to excessive heat in the engine.

- During operation, the genset reaches high temperatures in some parts of the engine, in ducts and the exhaust, avoid touching them until they are cold.
- During operation of the generator set, wear ear protectors to prevent hearing damage.
- Labels related to safety must be kept clean and in the places predetermined by the manufacturer.
- The fuels and lubricants are flammable, toxic, explosive and corrosive. We recommend keeping them in their original containers, never in glass containers, and storing them in protected places. If you smell fuel, do not start the genset or stop the genset if it is in operation.

2.5 SAFETY DURING MAINTENANCE

- Any checks and/or maintenance on the generator set should always be performed by qualified personnel.
- Maintenance operations must be carried out with the engine switched off and making sure that the generator set is not running (disconnect the batteries). If you are stopping the genset after it has been running for some time, allow it to cool down. Take care not to burn yourself as some components may be extremely hot when the genset has recently stopped.
- Before operating on any components of the electrical system, disconnect the batteries.
- All the doors on soundproofed gensets are protected against electric shock by means of equipotential conductors, which must not be removed under any circumstances. In gensets that have removable access panels, note that these panels will be protected by other means. In the event they have to be removed for cleaning purposes or the replacement of doors, do not forget to install the same conductors.
- Before opening the electrical panel, authorized personnel should take the following precautions:
 - Stop the generator set if it is in operation, and put the electrical panel into the locked position.
 - Disconnect any batteries from the generator set.
 - Disconnect the mains input to the panel.
- Periodically check both the tightening and isolation of the

- connections.
- With regards the various operations and/or maintenance procedures not specifically listed in the user manual, the manufacturer must be notified for approval.
- Do not make modifications to the product without the express knowledge and authorization of our Technical Department.
- Respect the characteristics recommended by the manufacturer with regards oil changes and fuel use. Do not use oils or fuels other than those specified by the manufacturer.
- Spare parts must correspond to the requirements defined by the manufacturer. Use only original spare parts. For spare parts only contact authorized spare parts distributors or workshops which are part of the HIMOINSA assistance network. To correctly identify the spare parts required, always specify the data indicated on the genset's identification plate, the type of engine and/or alternator and their respective serial numbers.
- Periodically check the status of the different components of the generator set, in particular anti-vibration devices, and the source of any vibrations and/or increases in noise levels.
- Periodically check for leakages of water, oil, fuel, and/or battery acid.
- Do not adjust the engine or other components of the generator set to obtain performance characteristics which differ to those envisaged by the manufacturer.
- Do not work on the fuel tank or the fuel supply conduits when the engine is hot or running.
- Wear protective gloves and goggles:
 - When using compressed air.
 - During the supply of inhibitors or antifreeze products.
 - During the replacement or supply of lubricating oil (hot engine oil may cause burns when being emptied, allow the oil to cool below 60°C).
- Wear a helmet when working in areas with suspended loads or equipment at head height.
- Always wear safety shoes and tight clothing.
- When working on live parts, always check that your hands and feet are dry. We recommend using insulating platforms to carry out the work.
- Change your clothes immediately if they get wet.
- Keep smeared rags in containers which are flameproof or suitable for this purpose.

- Do not leave rags on the engine.
- When starting an engine after repairs have been carried out, take precautions to stop the air intake if there is an excess in revolutions during the start up.
- Always keep the engine clean, removing oil, fuel and/or coolant stains. Do not use a high-pressure washer to clean the engine and the equipment, as some of the components may be damaged.
- Never start the engine with the speed control lever disengaged.
- Do not perform work alone which requires the presence of several people, especially when work must be performed on moving parts such as: switches, disconnectors, fuses and/or other live devices.

2.5.1. ENGINE COOLING CIRCUIT

- Never add coolant to a hot engine; first let the engine cool.
- Periodically check the coolant level and, if necessary, top up to the correct level using only liquid recommended in the engine's use and maintenance manual.
- Remove the radiator cap slowly. Typically the cooling circuits are under pressure, therefore hot liquid could be released violently if the pressure is discharged very quickly.
- In the event you want to remove the radiator fluid, there is an extraction valve available which has been designed for this use.
- Never use sea water or other corrosive or electrolytic products as a coolant.
- Periodically check the tension and state of wear of the pump/fan belts.

2.5.2. LUBRICATION CIRCUIT

- The crankcase should always have a minimum level of oil, which must be commensurate to the operation to be performed by the genset. It is recommended to periodically check this level using the engine dipstick marked with the corresponding identification sticker.
- If the oil is extracted for maintenance purposes, when it is replaced, fill the oil tray following the instructions in the engine use and maintenance manual, meeting the quality requirements of the combustion engine.
- Do not smoke or light fires while supplying the oil.

2.5.3. FUEL CIRCUIT

- The fuels used are highly flammable substances and can cause fires and explosions. Use extreme caution in the vicinity of the genset, the fuel installation and during fuel replacement, remembering that it is strictly forbidden to smoke, start fires and cause sparks. Pay attention not to spill fuel on the generator set.
- Always use the recommended fuels. Fuel of inferior quality or with a composition differing to that specified may damage the engine, affecting performance and service life.
- Do not fill the fuel tank while the engine is running.
- When filling the tank make sure no dirt or moisture enters the fuel system.
- Do not smoke or light fires during refuelling or replacement of fuel, and pay attention not to spill fuel on the generator set.

2.5.4. LIQUID COLLECTION TRAYS

- Possible spillage of fluids within the genset (fuel, oil, coolant or water) are caught in the collection vessels at the base of the container.
- It is advisable to regularly make sure there is no fluid in the collection vessels. If necessary, drain the vessels using the corresponding drainage holes, in the corners of the genset. If there is no such hole, drain the vessel using a liquid suction pump or the like.
- Never empty the liquid collection vessels onto the ground; do so into a suitable vessel.

2.5.5. EXHAUST CIRCUIT

- Visually check the exhaust circuit, if any gas leakage is detected, conduct repairs immediately, because inhalation is very harmful to health, as well as being a potential source of fire.
- Warning: very hot surfaces. Installation parts which are pre-assembled at the factory are protected from accidental impacts. The installer must insulate and/or protect accessory parts, the gas evacuation piping at the premises, the silencer supplied separately, etc.
- Drain the exhaust piping through the condensate discharge points, in

the event they are incorporated.

2.5.6. ELECTRIC START SYSTEM

- To prevent the engine's automatic start system from activating while working is being carried out on the engine, use the disconnecter installed for this purpose, if included, or disconnect the negative cable (-) before working on the engine.
- Keep connections tight and make sure the cable insulation is satisfactory.
- To prevent the danger of arcing, we recommend always connecting the positive terminal to the battery first, then the negative terminal (usually earth).

2.5.7. SYNCHRONOUS GENERATOR

- Do not carry out interventions with the genset in operation. Before intervening, put the genset into the LOCK position.
- Ensure the air inlets ventilating the generator are kept clean and, with some models, lubricate the bearings. In particular, check that the tightness and position of the electrical connections are correct.

2.5.8. CONTROL PANEL

- Before working on the control panel, disconnect the power supply and the battery/batteries, putting the genset into the LOCK position.
- The electrical control panels, like all electrical equipment, have moisture and dust. Check the correct operation of the anti-condensation heaters, where provided, and clean the air inlets used for ventilation.
- Periodically check that the pins securing the electrical connections are well tightened.

2.5.9. BATTERIES

- The batteries incorporated in the generator set are maintenance free.
- Periodically check the connections of the battery terminals to ensure they are clean, tight and protected from the weather.
- Never invert the positive and negative terminals of the batteries

when connecting them. An inversion may result in serious damage to the electrical equipment. Follow the wiring diagram supplied by the manufacturer.

- To disconnect the batteries use the disconnecter, in the event it is included, as it is installed for this purpose or disconnect the negative cable (-).
- Use extreme caution when replacing the batteries. Always wear protective clothing, gloves and goggles as the electrolyte inside the batteries is diluted sulphuric acid which is harmful if it comes into contact with skin or eyes. In the event it comes into contact with skin, remove all contaminated clothing and wash the affected areas with soap and water. In the event it comes into contact with eyes, rinse with water for 15 minutes and seek immediate medical assistance.
- In some countries the batteries are considered hazardous waste. Use appropriate containers or contact any organisations responsible for the collection of this waste.

2.6 ENVIRONMENTAL SAFETY

- Do not start the genset in confined areas without installing an exhaust pipe which vents fumes outside. Exhaust gases are harmful and can be lethal.
- Observe the rules and regulations concerning acoustic installations.
- Never run the engine without an air filter or without an exhaust.
- Replace the engine's exhaust and/or silencer if the noise level emitted is higher than that permitted by corresponding legislation.
- Maintenance (oil changes, cleaning the fuel tank, cleaning the radiator, washes, battery changes, etc.), storage and waste disposal must be carried out according to the regulations in the country of use.

2.6.1. INFORMATION SHEET ON THE ENVIRONMENT AND WASTE DISPOSAL IN ACCORDANCE WITH EN 82079-1

Only suitably qualified personnel may carry out generator set-related waste disposal work. By suitably qualified personnel, we mean staff who, thanks to their training and experience in the maintenance and repair of stationary diesel engines, are familiar with the health and environmental risks associated with the equipment and parts that are used in gensets.

Before starting work, a qualified electrician must check the electrical safety. Five

safety regulations must be observed:

1. Turn the unit off. (Disconnect the voltage)
2. Make sure it cannot be reconnected.
3. Check that there is no voltage.
4. Ground and short-circuit. (Installations from 1000 volts and above)
5. Cover or separate any adjacent live parts.

The safety data sheets of all equipment must be consulted and observed.

The following health and environmental risks may result from not disposing of waste properly:

- Burns
- Chemical injuries
- Intoxication
- Contusions
- Soil pollution
- Water pollution
- Air pollution

Contaminated materials such as starting batteries, used oil, coolants, fuel, detergents, filters and contaminated cloths should be disposed of professionally. Please consult your local waste disposal authority as to the appropriate recycling points.









To dispose of the generator set, we recommend that it be decommissioned without dismantling.



2.7 SAFETY AND INFORMATION STICKERS

The generator set has several safety and information stickers affixed to it in order to attract the attention of the operator or technician regarding potential dangers and with explanations on how to act safely.

A brief explanation of the location and information about each one is given below:

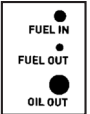
Drawing	Location	Information
	Located near the connections between the alternator and the engine. Where there are timing belts or transmission shafts	Warn of danger if a foreign object interferes with the genset's timing belts or any moving elements connected to them
	Located on parts of the genset that heat up during operation	Indicate which areas not to touch while the genset is running or shortly after it has stopped
	Located on the coolant filler cap	Warn that caution must be taken when opening the cap; the liquid is hot and can be discharged under pressure causing burns
	Located on the lifting points and next to the lifting hook	Indicates the point from which the genset must be lifted in order to move it
	Located next to the fuel tank cap. Depending on the model, it will be on the canopy or on the fuel tank	Indicates the location of the fuel tank and the filler cap
	Located next to the fuel tank cap. Depending on the model, it will be on the canopy or next to the engine	Indicates that the tank must not be topped up while the genset is in operation
	On either side of the bedplate skids	Indicates the recommended area for transporting the genset by forklift truck
	Located next to the oil dipstick and oil filler cap	Reports the location of the oil dipstick
	Located in the engine	Indicates that it is compulsory to read the instruction manuals before any kind of operation
	Next to the branch circuits of the earth protection devices	These are the points where the genset is protected from possible electrical discharges

Drawing	Location	Information
	Next to the circuit breakers protecting the genset	Output terminals for connecting the load, corresponding to each of the phases and neutral
	Located on the outer sides of the genset, inside or adjacent to the protection and control panel	Indicates the position of the emergency stop button that allows the equipment to be simultaneously stopped
	Located in the protection and control panel	Warn of danger due to the presence of voltage
	Always located next to the motorised circuit breaker	Reports that it is prohibited to manipulate the genset with the switch connected
	Located on the external part of soundproofed gensets, next to the protection and control panel	Informs and warns about the noise emitted by the soundproofed genset, indicating the specific acoustic power value for each of the generator sets
	Located on the external part of standard static gensets, on an easily visible part of the alternator	Informs and warns about the noise emitted by the standard static genset, recommending the use of helmets and indicating the specific acoustic power value for each of the generator sets
	Positioned on the protection and control panel, above the motorised circuit breaker	Warning and reminder about replacing the exhaust system covers before starting the genset
	Located in the protection and control panel	Reports that it is necessary to check that there is a sufficient level of fuel in the tank before each start
	Located inside the container doors, next to the locking pins	Reports that, when the doors have been opened, to close them it is necessary to loosen the locking pin
	Located above the fuel and oil connecting valves on the side of the protection and control panel container	Notes the function performed by each of the fuel and oil quick connecting valves

Drawing	Location	Information
	Located on the exhaust silencers	Inform and warn that the container doors must be kept closed while the genset is in operation
	Positioned on the bracket where the three-way valve is located.	Make known and warn that when starting up the genset, the external tank must be correctly connected and the three-way valve lever must NOT be in the central position.

Change any stickers which are missing or illegible.

NOTE:

It is possible that some of the stickers indicated are not necessary for your generator set model, and are not included with the genset.

3. GENERAL DESCRIPTION

The generator set is powered by industrial 4-stroke diesel combustion engines, with compression ignition, naturally aspirated or turbocharged and/or aftercooled, with the arrangement of the cylinders in line or V-type, depending on the engine model and cooled air and/or water. The engines used are fitted with all the accessories that provide high reliability in the power supply.

To generate the electricity demanded, alternators are used with a horizontal axis, synchronous, 2 or 4 pole with a frequency of 50 Hz (1500 or 3000 rpm) or 60 Hz (1800 or 3600 rpm) and class H insulation, except in cases where specific requirements have been made by the customer.

The engine and alternator are coupled and mounted on the supporting bedplate or frame, formed by a thin sheet structure made of high strength steel, which in turn incorporates the battery system with its corresponding clamping fittings. This coupling between the generator set and the bedplate includes elastic supports (anti-vibration elements) designed to reduce engine vibration transmitted to the foundations on which the generator set is installed.

The fuel tank can be included on the supporting bedplate or be external to the genset. Installation must be performed properly according to the instructions in this manual.

The engine exhaust can be muffled using a high attenuation silencer that guarantees an appropriate reduction in noise emission levels.

The cooling system of the genset is generally formed by a radiator, a high-powered fan, expansion tank, centrifugal pump, thermostatic valve and temperature sensor, among other possible components. The water used as a coolant is mixed with additives, thereby lowering the freezing point and protecting against corrosion.

For soundproofed static gensets, the canopy is made of sheet steel of suitable thickness, duly treated to provide a perfect finish. Inside it is coated with a fire retardant sound-absorbing material. In the air inlet and outlet areas, the canopy is provided with corresponding ducts, designed to channel air without the logical reverberations occurring in a forced air conduction. The door locks are provided with a key to ensure non-authorized persons cannot operate the equipment, even from the control part of the genset. The same key can be used on all the doors of each genset.

The generator set canopy incorporates, on all gaskets, an external seal made from EPDM foam sponge rubber and/or a high-density polyurethane-based silicone, which minimises water ingress inside the generator set.

NOTE

If the user removes this seal to carry out any maintenance or repairs on the generator outside or within the established warranty period, HIMOINSA accepts no responsibility for any damage that might be related to water ingress inside the generator set.

These gensets may include a control and/or operation panel, consisting of a control unit and a series of buttons; and a protection panel with a circuit breaker, among other components.

The generator sets are used for two main types of service:

- Continuous service gensets. Used for electricity production in areas where there are no other sources of production and have various applications (motive power, electricity, heating, etc.).
- Emergency service gensets. These are used in the event of power outages that could cause serious problems for people, property damage, and/or financial costs (hospitals, industrial facilities, airports, etc.) or to meet peak consumption.

According to the assigned destination, gensets are subdivided into:

- Gensets for use on land
- Gensets for use at sea

Regarding gensets for use on land, according to the intended use, there are two envisaged types:

- Static gensets (fixed installations)
- Portable gensets (mobile installations)

The two versions in turn can be subdivided into a wide range of models according to the operating modes and requirements:

- Manually operated gensets
- Automatically operated gensets
- Continuity gensets

This manual provides general information for installation and use of HIMOINSA gensets with manual and automatic operation.

3.1 COMPOSITION OF THE GENERATOR SET

Each generator set looks different due to the various sizes and configurations of each of the main components.

A standard static genset usually consists of:

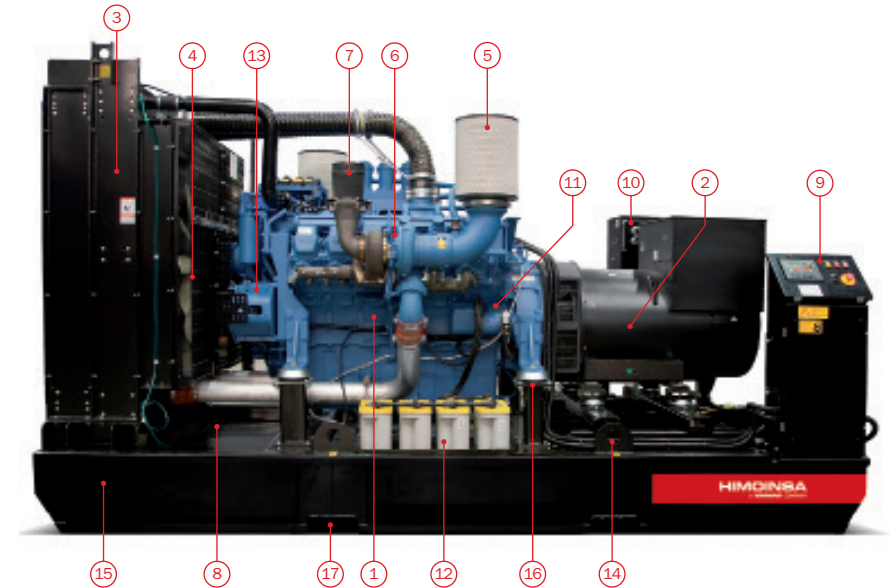

1. Combustion engine	10. Protection panel/power cables output (at the rear of the image)
2. Alternator	11. Starter motor
3. Radiator	12. Starter batteries
4. Fan	13. Battery charging alternator
5. Dry air filter	14. Lifting points
6. Turbocharger*	15. Bedplate
7. Exhaust outlet	16. Anti-vibration devices
8. Internal fuel tank	17. Lifting coupling skids
9. Control panel	

*Depends on the combustion engine model

With the soundproofed static genset, in addition to the parts described for the standard static genset, the following components are found on the canopy:



1. Control Panel	7. Air outlet grid (top view)
2. Power cables output	8. Key locks
3. Lifting point	9. Radiator filler cap (top view)
4. Exhaust outlet tilting cap	10. Fuel filler cap
5. Lifting coupling skids	11. Oil extraction/supply connection area*
6. Emergency stop button	

*Depending on the type of generator set, these connections can vary their utility or not be incorporated.



1. Control Panel	6. Key locks
2. Side cables output	7. Exhaust outlet tilting cap
3. Front cables output	8. Air outlet grid
4. Anchor points for fastening the hoisting kit (x4)	9. Radiator filler cap
5. Lifting coupling skids	10. Emergency stop button

3.2 DIMENSIONS AND TECHNICAL SPECIFICATIONS

The information regarding the characteristics of a generator set is included in the genset's data sheet.

NOTE

For other power outputs and components, consult the factory.

3.3 IDENTIFICATION PLATE

Generator sets, as well as their components, incorporate identification plates that provide the following information:

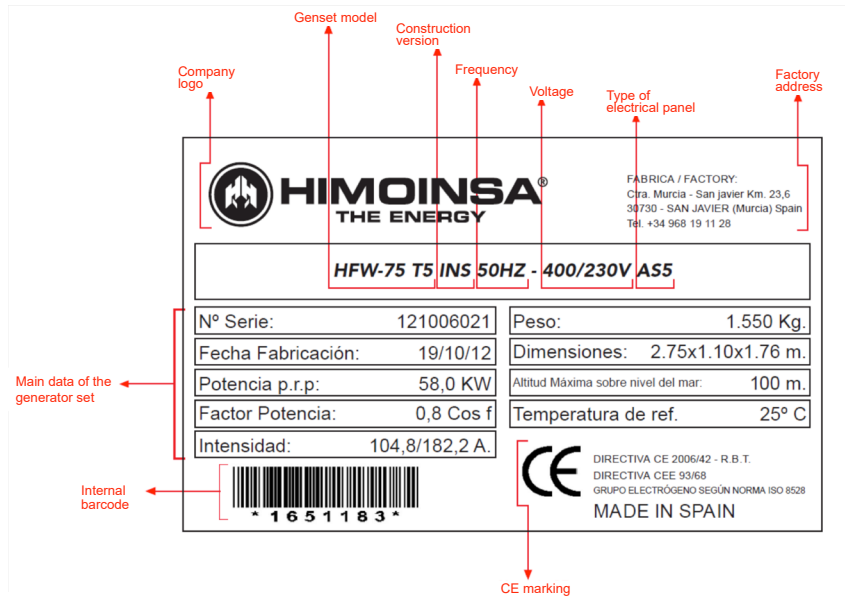

In most cases, the identification plate will be located on the electrical panel.

3.4 NOISE

Information about the Noise Protection Level of the genset and the Level of Sound Pressure Emissions at the Operator's Workstation is specific to each generator set. This data can be found in:

- Weighted sound power level: check this value in the EC declaration and the marking on the equipment.
- Uncertainty: check with the manufacturer for each model.
- Sound pressure level: check with the manufacturer for each model.

Sound Power Level measured according to Directive 2000/14/EC as amended by Directive 2005/88/EC.

4. UNLOADING, HANDLING AND TRANSPORTATION

4.1 IMPORTANT WARNINGS

4.1.1 CHECKING THE MATERIAL

When receiving the genset it is a good idea to check that the material received corresponds to that requested, against the delivery note accompanying the genset, and verify that the material is not damaged. To do so, open the corresponding packaging.

If damage is discovered, notify the transport company immediately so that they can report the corresponding event to the insurance company. HIMOINSA states that all deliveries shall be at the sole risk of the Customer.

4.1.2 SAFETY

Unloading, handling and transportation of the generator set must be carried out by suitably qualified personnel using the appropriate lifting machinery and materials for this kind of load.

To avoid the risks involved in these activities, it is important to ensure the correct use of work equipment by trained personnel, checking that the equipment and lifting elements used (safety hooks or clamps, slings, chains, etc.) are in good condition and are adequate for the loads to be moved, as well as monitoring and displaying information so that loads do not pass above other workers or third parties.

Before each operation, it is necessary to check the position and proper grip of the lifting elements and the good condition of the attachment points; always using the lifting points and skids intended for such operations as directed in this manual, previously verifying the proper condition of the points mentioned.

Do not load any other objects in addition to the generator set that could modify its weight and centre of gravity.

4.2 UNLOADING AND HANDLING

4.2.1 GENERAL INSTRUCTIONS

It is necessary to check and comply with the safety requirements specified in Section 4.1 Important warnings.

According to the weight of the genset, it is necessary to check that the machinery and the lifting elements which are going to be used are able to carry the load in a safe and controlled manner, keeping the genset in a level horizontal position.

Before unloading, it is important to ensure the floor is able to support the load of the generator set. If in doubt, we recommend laying evenly distributed pieces of wood of sufficient strength.

We recommend placing the genset in a clear, easily accessible position which is as close as possible to the installation or transportation area. Similarly, prior consideration should be given to the movement of the load and the route taken, so that there are no obstacles or power lines which may be affected by the loads.

4.2.2 INSTRUCTIONS FOR USE OF SLINGS

We recommend checking the correct attachment of the lifting apparatus to the marked lifting points, tighten slightly while checking the stability and safety of the operation and make sure the container is properly secured after being raised off the ground.

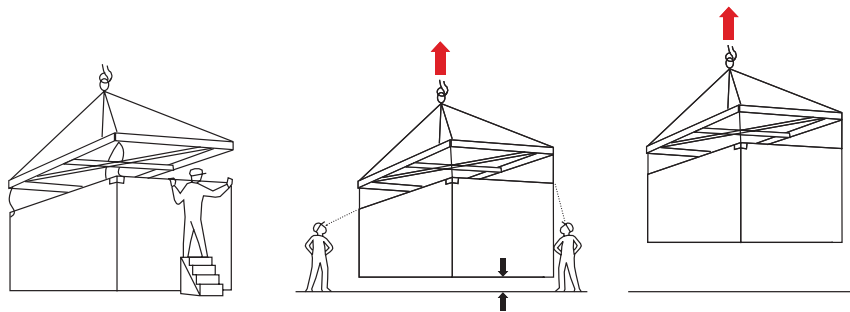

Having performed these checks, proceed with the lifting and handling of the container, with smooth controlled movements, avoiding tilting. Choose a location in accordance with Section 4.2 Unloading and handling. General instructions. Once it is placed on the ground, after checking the correct stability of the container, the slings may be loosened and removed.

These instructions are generic, and are valid for all generator sets which are to be subjected to lifting, unloading or handling using slings as lifting elements, taking into account the particularities of each version as shown below:

STANDARD STATIC GENSET

Lifting devices (slings) may only support the lifting points designed for such use, avoiding contact with any of the components forming the generator set. In the case of using slings to lift the generator set, we recommend using one of two lifting methods:

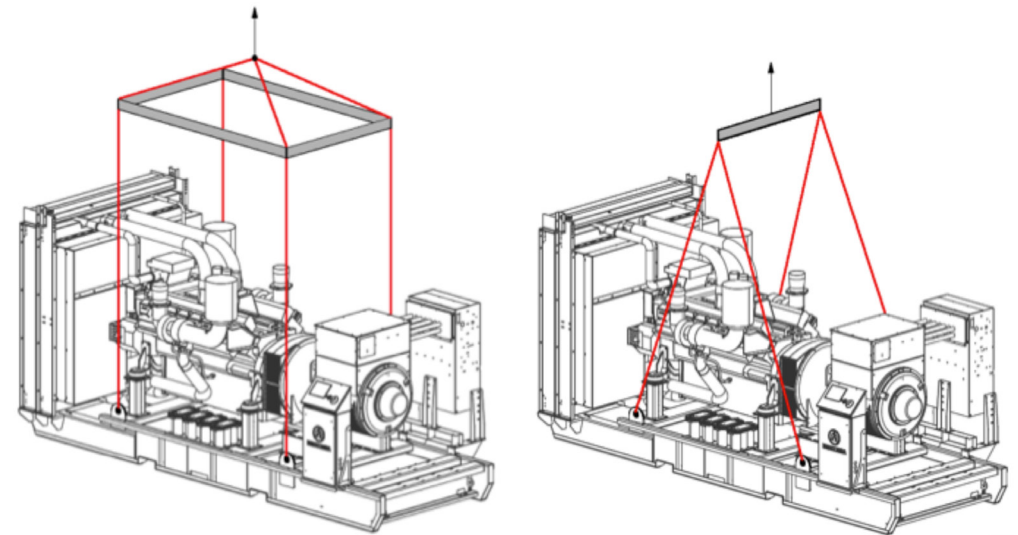

SOUNDPROOFED STATIC GENSET

The attachment points of the lifting elements may vary depending on the type of generator set canopy.

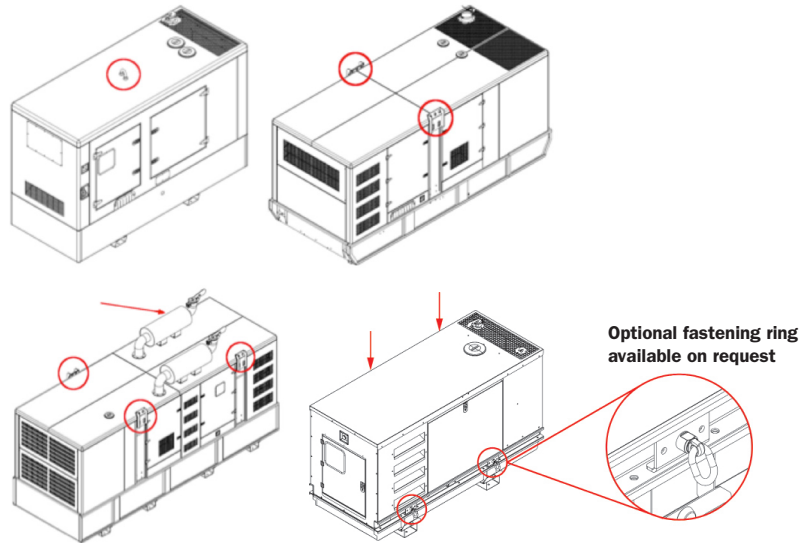

In the same way as standard static gensets, slings may only come into contact with the genset via the fastening elements on the marked lifting points, hence avoiding possible damage during handling of the genset. In the case of using slings to lift the genset, we recommend employing the same lifting methods used for standard static gensets.

Check for apparent signs of deformation or corrosion on the attachment points of the lifting elements and the structure itself (nuts, bolts, brackets, etc...) before lifting the genset. The lifting points or attachment points of the lifting elements have a limited useful life and therefore must be replaced every 10 years.

SOUNDPROOFED STATIC GENSET IN CONTAINER

The standard containers used are of the type ISO Series 1, complying with the specifications set out in ISO 668 and have lifting points or corner pieces according to ISO 1161. Upon request from the customer, it is possible to use containers with special dimensions.

To ensure the safety of the materials and persons, the following lifting operations are recommended for unloading and handling the container, as envisaged by ISO 3874 according to the type of container, in a controlled, level manner and avoiding any possible tilting of the genset. Where the dimensions of the containers are characterised in the following way:

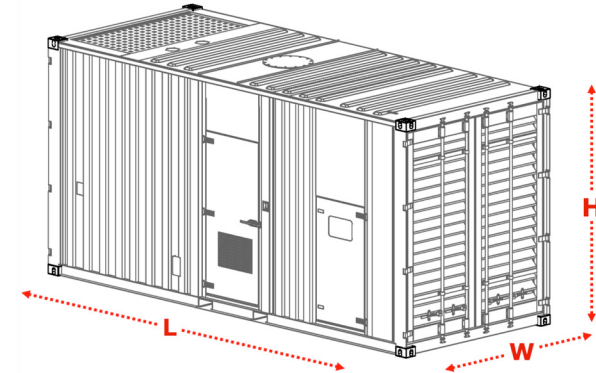

Elevation using the upper lifting points

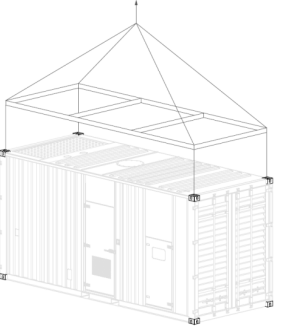
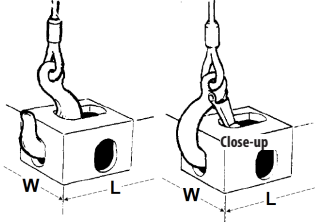
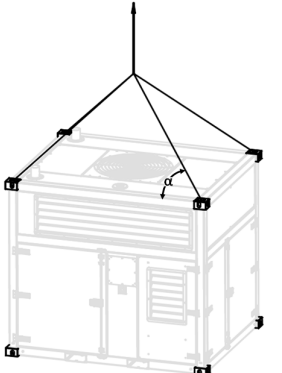
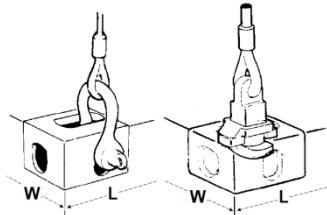
Acceptable containers	Types of couplings
 <p>40' 30' 20' 10'</p>	<p>Regular hook: Introduced from the inside out. Safety hook: Introduced from the inside out.</p>  <p>W L W L</p>
 <p>10' ($\alpha=60^\circ$)</p>	<p>Shackle. Manual coupling bolt: They cannot be rotated 38 mm max. while the container is suspended by them.</p>  <p>W L W L</p>

Elevation using the lower lifting points

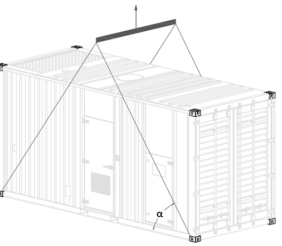
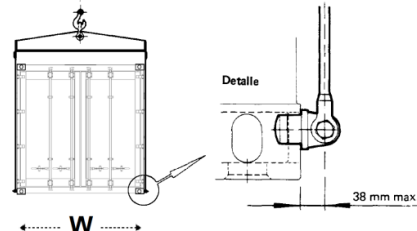
Acceptable containers	Types of couplings
 <p>40' ($\alpha=45^\circ$) 30' ($\alpha=45^\circ$) 20' ($\alpha=45^\circ$) 10' ($\alpha=60^\circ$)</p>	<ul style="list-style-type: none"> • The lifting device may only support four corner pieces, without coming into contact with any other part of the container. • The maximum distance between the sling or chain and the container shall be 38 mm.  <p>W</p> <p>Detalle</p> <p>38 mm max.</p>

4.2.3 INSTRUCTIONS FOR USE OF FORKLIFT TRUCKS

The generator incorporates skids for coupling the lifting machinery, where the arms of the forklift truck must be inserted, ensuring that they do not exit the guide that is incorporated in the container for this purpose. If possible, it is recommended that the arms be longer than the width of the container, and in any case no longer than 1825 mm.

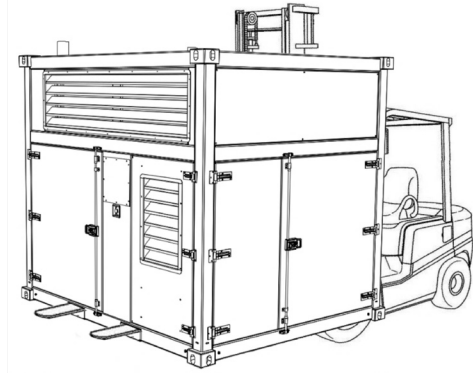

According to the weight of the genset, the machinery used must be checked to ensure it is able to carry the load in a safe and controlled manner.

We recommend using this method of raising generator sets for the standard static version, soundproofed static version and 10 and 20 feet containers, using in all cases the skids for coupling the lifting arms.

NOTE
This method is not recommended for lifting 30 to 40 feet containers.

A forklift may only be used to transport the generator set, if excessive heights are avoided during transport and if it is possible to carry out the appropriate operations in a controlled and safe manner. Under no circumstances may lifting be carried out by placing the forks under the base of the genset, outside the coupling skids.

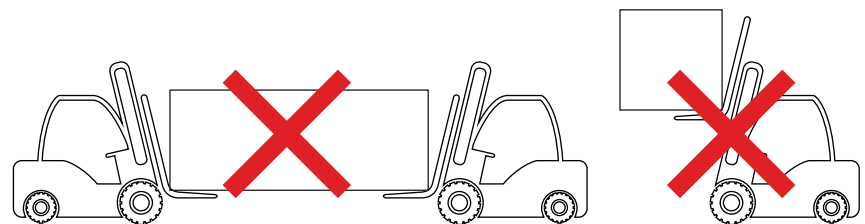

4.3 TRANSPORT

Transportation of generator sets, regardless of the model, should be conducted according to safety standards in force in the country where this operation is carried out, whether for land, sea or air transport.

Before performing genset transportation, disconnect the batteries and ensure the valves and caps included (oil, coolant, etc.) are kept tightly closed, thus avoiding spills.

For road transportation, it is recommended that the means of transport are of sufficient quality as not to damage the generator set, keeping the genset in a horizontal position.

5. MOBILE GENERATOR SETS

HIMOINSA generator sets can be supplied in a mobile version. Depending on the type of trailer used, mobile gensets are divided into:

- Low speed mobile generator sets, for use inside private spaces.
- Mobile generator sets authorised for high speed, suitable for circulation in public spaces.

When towing a mobile generator set, it will be necessary to respect the traffic laws and regulations in force in the country where this operation is being carried out.

The trailer is designed to support the weight* of the specific generator set that is sent with it, with the respective safety margins. Do not therefore modify the weight of the generator set, do not allow persons to sit on it and do not set objects on the trailer or the generator set.

NOTE

***Weight including liquids in the radiator and the crankcase but excluding fuel in the tank. This data is available both in the technical specifications and on the machine's identification plate.**



The function of the front support wheel is to provide stability to the trailer during parking and while adjusting the height of the hook using the adjustment crank. During the towing operation, this wheel must be folded or retracted.

5.1 PRIOR CHECKS

Before mounting a trailer, inspect all the components of the tow vehicle and generator set, with special attention to the trailer hitch, ensuring the absence of signs of breakage or excessive wear.

Also, check the tightness of the wheels and the pressure and good condition of the tyres.

Also check that all the doors and covers of the canopy, and tool boxes in the event they are included, are latched closed and locked, and that the charging and earthing cables and external fuel pipes are disconnected.

It is advisable to mount the genset onto the trailer without fuel in the tank, ensuring maximum stability during this operation.

5.1.1 INSTALLATION

The mobile generator sets are designed for outdoor use, therefore when carrying out outdoor installation follow the instructions in Section 7.2 Outdoor installations.

If you would like to install the mobile generator set in an indoor area, it is important to take into account the instructions in Section 7.3 Indoor installations, taking very much into account the ventilation of the genset and the evacuation of exhaust gases.

NOTE

In the case of use in areas other than the reference environmental conditions, go to Section 6.3 Derating for operating environmental conditions.

5.2 LOW SPEED MOBILE KIT

The low speed mobile kit is designed for displacement inside private spaces, with circulation not permitted in public spaces. The standard trailer includes: coupling hook, adjustable front support wheel and signalling reflectors.

Keep in mind that the low speed mobile kit cannot be braked as it does not include an inertia brake, unless expressly requested.

It is possible to incorporate into special orders, some of the optional accessories included for the trailers approved in Section 6.3 Approved high speed mobile kit.



5.2.1 COUPLING

To successfully hitch the trailer to the towing vehicle, these guidelines should be followed:

- Chocks on both sides of the wheels to prevent the trailer from moving.
- Completely raise and lock the rear supports, if included.
- Release the parking brake, if included.
- Adjust the height of the coupling ring to the level of the hook on the towing vehicle using the front wheel adjustment crank.
- Hook, close and/or lock the towing device.
- Retract/raise the front support wheel, to the highest possible position, using the locking pin included in the joint, lowering the trailer to the desired height.
- Remove any obstacles or chocks under the wheels.

5.2.2 UNCOUPLING

Uncoupling the trailer must be carried out on a horizontal, flat surface which is able to support the load and is preferably dry. In addition, the guidelines below should be followed:

- Chocks on both sides of the wheels to prevent the trailer from moving.
- Lower the front support wheel and level the coupling, leaving it ready for the separation of the towing vehicle.
- Separate the mobile generator set from the towing vehicle.

- Keep the genset in a level horizontal position using the front support wheel crank.
- Lowering and locking the rear supports, if included.
- Release the parking brake, if included.

5.3 APPROVED HIGH SPEED MOBILE KIT

The approved high speed mobile kit is able to circulate in public spaces, although it is necessary to adapt the speed to the road conditions and the performance of the trailer.



These types of trailers include: fixed or articulated drawbar, inertia and parking brake, safety brake cables, adjustable front support wheel, lockable rear support bars, signalling reflectors and rear lighting via electrical wiring.

The size of the trailer and the number of wheels will depend on the size of the generator set.

With special orders it is possible to include optional accessories such as air suspension, ABS braking system, spare wheel and back-up beeper, among others.

The trailer indicator lights are mandatory when driving on public roads. These include the reflective stickers, red rear lights, direction indicators and braking lights. For correct operation it is necessary to connect the electrical wiring of the trailer to the towing vehicle's electrical circuit.



We recommend fitting a safety brake cable to the towing vehicle, using one of the following coupling methods:

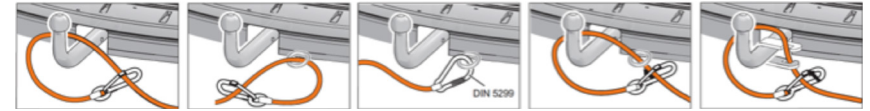

Before towing the trailer, check the correct operation of the light indicators, conduct a braking test, and check the proper operation of the locking system and inertia brake.

NOTE

The indications for use of approved high-speed mobile kits are generalised for standard trailers. In the event that your trailer incorporates a special component which is not mentioned, consult the trailer documentation or contact the HIMOINSA Technical Department or your local dealer.

5.3.1 COUPLING

To successfully hitch the trailer to the towing vehicle, these guidelines should be followed:

- Chock the wheels to prevent the trailer from moving.
- Completely raise and lock the rear supports.
- Adjust the height of the coupling ring to the level of the hook on the towing vehicle by loosening the locking levers of the drawbar arms.
- Hook, close and/or lock the towing device.
- Retract/raise the front support wheel, to the highest possible position, using the locking pin included in the joint, lowering the trailer to the desired height.
- Connect the electrical wiring of the trailer to the towing vehicle's electrical circuit.
- Secure the safety brake cable to the hook on the towing vehicle.
- Remove any obstacles or chocks under the wheels.
- Release the parking brake.

5.3.2 UNCOUPLING

Uncoupling the trailer must be carried out on a horizontal, flat surface which is able to support the load and is preferably dry. In addition, the guidelines below should be followed:

- Chock the wheels to prevent the trailer from moving.
- Lower the front support wheel, lift the trailer and level the coupling, leaving it ready for the separation of the towing vehicle.
- Disconnect the electrical wiring and safety brake cables.
- Separate the mobile generator set from the towing vehicle.
- Keep the genset in a level horizontal position using the front support wheel crank.
- Lowering and locking the rear supports.
- Engage the parking brake.

6. OPERATING CONDITIONS

6.1 WARNINGS IN THE CASE OF MISUSE

The generator set which HIMOINSA has supplied is designed for the production of electrical energy according to the environmental and operating conditions and limits indicated or agreed in the contract. Any modifications to such conditions and limits must be communicated directly to the factory or via the organization of authorized repair centres to obtain optimum performance and, if necessary, to make changes and/or new calibrations to the genset.

The generator set is a machine which converts the potential thermal energy contained in the fuel into electrical energy; and is intended to supply distribution installations which must be carried out by experts pursuant to current regulations. While the power levels available may be lower than those of a public supply system, the danger posed by the electrical energy is the same. The generator set is a production control unit which, in addition to the risks of an electrical nature that are similar to those of the power supply from the public grid, also presents dangers arising from the presence of fuel substances (fuel itself or lubricating oils), rotating parts and waste by-products (exhaust fumes and cooling and irradiation heat).

While it is possible to exploit the heat contained in the exhaust fumes and in the cooling circuit to increase the thermal efficiency of the process, this application must be set up by specialized technicians in order to obtain a reliable and safe installation for people and materials and to avoid invalidating the warranty.

Any other use that has not been previously agreed with HIMOINSA should be considered as improper and as such is not acceptable.

6.2 STANDARD REFERENCE ENVIRONMENTAL CONDITIONS

6.2.1 GENERATOR SET

The reference environmental conditions for generator sets, according to ISO 8528-1, are:

- Ambient temperature 25°C (298 K)
- Ambient pressure 100 kPa (100 masl)
- Relative humidity 30%

6.3 DERATING FOR OPERATING ENVIRONMENTAL CONDITIONS

In the event of environmental conditions of installation and operation, other than those indicated in the previous section, it will be necessary to carry out appropriate power losses or “derating”, both for the engine and the alternator which it is coupled to, and therefore the electrical power supplied by the assembly.

When making a quote request, the User/Customer should clearly state the actual environmental conditions in which the generator set will operate. Since derating and declassification must be fixed at the time of drawing up the contract, so that both the engine and the generator are dimensioned properly.

In particular, the User/Customer must communicate the following environmental conditions under which the generator set will operate:

1. The lower and upper ambient temperature limits.
2. The altitude above sea level or, preferably, the minimum and maximum barometric pressure values in the installation site; in the case of mobile gensets, the minimum and maximum limits of altitude above sea level.
3. Humidity values in relation to the temperature and pressure of the installation site, with special attention to the value of relative humidity at the maximum temperature.

4. Any other special environmental conditions that may require special solutions or shorter maintenance cycles, such as:

- Dusty and/or sandy environments
- Marine type environments
- Environments with potential chemical pollution
- Environments with radiation
- Operating conditions in the presence of large vibrations (e.g. areas subject to earthquakes or other external vibrations generated by nearby machines)

NOTE

When the actual environmental conditions are not specified in the contract phase, the power of the genset is understood to refer to the standard conditions for the generator set according to ISO 8528-1.

If the actual environmental conditions change in the future, it will be necessary to contact the HIMOINSA organization to calculate the new power losses and to make the necessary calibrations.

For diesel engines, this derating is determined by the corresponding engine manufacturers, to find out this information contact HIMOINSA's Technical Department or request it from your usual dealer.

Derating the alternator is less important than the combustion engine; as such the derating of the generator set generally resembles the derating of the engine.

EXAMPLE: SIZING OF THE ALTERNATOR

A generator set of 64 kW (80 kVA) under standard conditions with the engine at 25°C, 100 masl and 30% relative humidity.

The genset consists of:

- A supercharged engine of 72 kW at 25°C, 100 masl and 30% RH.
- An alternator of 80 kVA delivered at 40°C and 1000 masl; with a performance of 89%.

If you want to check the maximum power that the genset can deliver at 1500 masl and a temperature of 45°C.

Where the reduction coefficients for the indicated alternator are:

Table 1
Alternator power reduction coefficients according to the various environmental conditions

Ambient temperature (°C)	30	35	40	45	50	55	60
Reduction coefficient K_1	1.05	1.03	1.00	0.96	0.92	0.88	0.84
Altitude (masl)	1000	1500	2000	2500	3000	3500	4000
Reduction coefficient K_2	1.00	0.97	0.95	0.92	0.89	0.86	0.83

The engine derating coefficient indicated by the manufacturer of the engine is 0.75 for the environmental conditions required by the genset. Therefore, engine power, under the specified conditions, will be:

$$P_{\text{motor}} = 0.75 \cdot 72 = 54 \text{ kW}$$

Given the performance of the alternator, the power of the genset is:

$$P_{\text{genset}} = 54 \cdot 0.89 = 48 \text{ kW}$$

Finally it is necessary to check that the alternator is appropriate for the power that the genset is able to deliver, which has just been calculated.

To do this, it is necessary to obtain the alternator derating via the reduction coefficients K_1 and K_2 shown in Table 1 above or otherwise as directed by the manufacturer of the alternator.

Therefore, for the environmental conditions of the genset (45°C and 1500 masl) the following reduction of apparent maximum reference power is obtained for the alternator:

$$S_{\text{alternator}} = K_1 \cdot K_2 \cdot S_{\text{ref}} = 0.96 \cdot 0.97 \cdot 80 = 74.4 \text{ kVA}$$

Therefore, the active power for a power factor of 0.8 will be:

$$P_{\text{alternator}} = 74.4 \cdot 0.8 = 59.2 \text{ kW}$$

It is evident that the alternator is oversized with respect to the power that the genset can deliver (48 kW) under the environmental operating conditions required.

NOTE

For greater precision, refer to the manufacturer's documentation.

6.4 OPERATING LIMITS

The User/Customer should communicate, during the quote request phase, all the operating conditions that may affect the operation of the generator set. In addition to the environmental conditions described in the previous paragraph, special attention should be given to the characteristics of the loads to be connected, the power, the voltage and the power factor. It is necessary to determine and indicate the load connection sequence with a great deal of accuracy.

6.4.1 POWER

The generator set power is the active power (expressed in kW) delivered via the generator's terminals, at the voltage and frequency and under the environmental conditions established.

According to ISO 8528-1, the various power outputs of the generator sets are defined as follows:

CONTINUOUS POWER (COP)

This is the maximum power available for use under constant loads for an unlimited number of hours per year between the maintenance intervals prescribed by the manufacturer and under the established environmental conditions.

PRIME POWER (PRP)

This is the maximum power available for use under variable loads for an unlimited number of hours per year between the maintenance intervals prescribed by the manufacturer and under the established environmental conditions. The average consumable power over a period of 24 hours must not exceed 70% of the PRP.

EMERGENCY STANDBY POWER (ESP)

This is the maximum power available for use under variable loads in the event of a network power outage or under test conditions for a limited number of 200 hours per year between the maintenance intervals prescribed by the manufacturer and under the established environmental conditions. The average consumable power over a period of 24 hours must not exceed 70% of the ESP.

6.4.2 CHARGING OUTLETS

When a load is applied to a generator set, this often causes voltage and frequency transients. The extent of such deviations depends on the power value, both active (kW) and reactive (KVAR) of the load variations, depending on the genset's characteristics (power and dynamic characteristics).

The genset's characteristics are result of the combination of the characteristics of the combustion engine and alternator.

If further information is required, you may request the load impacts reports produced according to standard ISO 8528-5 by contacting the HIMOINSA Technical Department.

When the capacity of the charging outlet is an important requirement, the Customer/User should clearly indicate this to HIMOINSA and must provide all the information related to the various loads to be fed; their possible division into gensets and the connection sequence. All this helps achieve the best dimensioning of the genset and avoid both uneconomic oversizing and dangerous undersizing.

6.4.3 POWER FACTOR (COS ϕ)

The power factor is defined as the ratio between the active power (kW) and apparent power (kVA), describing the amount of electricity consumed which has been transformed during operation. Therefore, it is a value which depends on the characteristics of the load.

HIMOINSA generator sets, equipped with an alternator, can deliver both the active power and reactive power required by the load but, while active power is delivered by the combustion engine (transforming mechanical power into electrical power by means of the generator) reactive power is delivered by the alternator.

If the nominal power factor is 0.8, the nominal apparent power will be 1.25 times the nominal active power.

For operation with values other than 0.8, the following should be taken into account:

LOAD WITH COS ϕ BETWEEN 0.8 AND 1

At nominal active power the alternator works perfectly with cos ϕ entre values between 0.8 and 1. To avoid overloading the engine, it is essential not to exceed the nominal active power.

LOAD WITH COS ϕ < 0.8

The alternator, for the reference plate value of cos ϕ = 0.8, is overloaded more as it approaches cos ϕ of 0. Therefore the reactive power to be delivered increases as the cos ϕ decreases. The generator reduces power according to the indications supplied by the manufacturer. Under these conditions the combustion engine generally presents high power.

By way of example, Table 2 is presented for the determination of these reductions in power.

Table 2

Coefficients indicative for reducing power of a generator according to cos ϕ

Power factor (cos ϕ)	1	0.8	0.7	0.6	0.5	0.3	0
Reduction coefficient	1.00	1.00	0.93	0.88	0.84	0.82	0.80

NOTE

For greater precision, refer to the documentation provided by the manufacturer of the genset.

6.4.4 SINGLE PHASE LOAD

The generator sets can become loaded with unbalanced loads reaching a maximum of the nominal current in each phase.

This means that between two phases (e.g. between L1 and L2) no more than 0.58 of the three phase nominal power of the genset can be introduced given that:

$$\frac{\sqrt{3}}{3} = 0.58$$

Similarly, between one phase and neutral (e.g. between L3 and neutral) no more than 0.33 of the plate three phase nominal power can be introduced:

$$\frac{1}{3} = 0.333$$

It should be remembered that during single phase operation or with unbalanced loads, the voltage regulator cannot maintain the expected voltage tolerances.

6.4.5 START UP OF ASYNCHRONOUS ENGINES

Starting asynchronous motors by means of a generator set present problems, as engines with squirrel cage rotors have starting currents eight times the rated current ($I_{\text{start-up}} = 8 I_n$), and a low power factor.

Under these conditions, the current absorbed by an asynchronous engine (or by engines which start simultaneously) during starting, must not exceed the maximum current that the generator can deliver in a short time, with a tolerable voltage drop and not exceeding overtemperature limits.

To prevent excessive oversizing of the generator set, the following systems can be employed for the cases raised:

VARIOUS ENGINES

Divide them among several gensets which are each introduced according to a preset sequence, at intervals of 30-60 seconds.

A SINGLE ENGINE

Where permitted by the coupled operating machine, using a reduced voltage starter system (star/delta or auto-transformer) or, for higher power engines with wound rotor and rheostatic starter.

In the case of star/delta starting, the voltage in each phase is reduced and the starting current ($I_{\text{start-up}}$) is reduced at the same rate, this being:

$$\frac{1}{\sqrt{3}} = 0.58$$

Therefore, in the case of an engine starting currents six times the nominal value $I_{\text{start-up}} = 6 \cdot I_n$ of direct starting, with star/delta starting $I_{\text{start-up}}$ this will be reduced to approximately 3.5 times the I_n , and consequently the power required to generator will be reduced by 58%.

$$I_{\text{start-up}} = \frac{1}{\sqrt{3}} \cdot 6 \cdot I_n = 3.5 \cdot I_n$$

In all cases, both with direct starting and reduced voltage starting, it is necessary to control the devices and users connected to the user circuit, trying to avoid possible failures (e.g. contactors opening) caused by a transitory voltage drop during starting.

6.4.6 LOW LOAD PROFILE

The endothermic engines that are used in generator sets have been designed to use as much power as possible, from 30 to 100% of the declared maximum power.

The actual engine load depends on the power that the installation demands. The engine and its components are primarily designed to operate in the high load or power range rather than in continuous low load mode.

CONSEQUENCES OF OPERATING UNINTERRUPTEDLY IN LOW LOAD MODE

Operating uninterruptedly in low load mode can lead to higher oil consumption and consequently to a manifestly greater deposit of carbonized oil or oil residue in the engine, as well as in the suction and exhaust system.

The emergence and persistence of residue has a negative impact on the functional behaviour and on the lifetime of the engine. As a result, maintenance tasks tend to increase.

In addition, when an engine is operating in low load mode, it cools down, which means that the fuel is only partially burned, which can in turn produce a white smoke with high hydrocarbon emissions.

Due to the low fuel temperature, the percentage of unburned fuel in the oil increases. These problems are due to the fact that the piston rings, the piston itself and the cylinder do not dilate enough to ensure a good seal and as a result the oil rises and is expelled through the exhaust valves. This means that the diesel oil passes into the crankcase, degrading the quality and the properties of the lubricant.

Frequent and continued use of generator sets with power loads of less than 30% of the maximum power value can lead to the following failures over time:

- Increase of exhaust smoke.
- The presence of traces of fuel in the engine oil.
- Excessive wear of the turbocharger.
- Oil leaks in the body of the turbocharger.
- Increased pressure in the gearbox and the crankcase (Blowby).
- Excessive deposit of carbon residue on the surfaces of the valves, valve seats, pistons and the exhaust manifold.
- Hardening of the surfaces of the cylinder liners.
- If such a system exists, lower efficiency of the exhaust gas treatment system (ATS) which may activate the forced regeneration cycle of the DPF.

RECOMMENDED CORRECTIVE MEASURES

To avoid any incident and ensure the correct use of the generator set, HIMOINSA recommends that you avoid operating it uninterruptedly in low load mode, or that you reduce such usage to minimum periods of time. The use of generator sets in low load conditions for more than 15 minutes should be avoided.

During the weekly operation tests, the no-load operating time should be limited to a maximum of 15 minutes, until the battery charge values have returned to normal.

The generator sets should be operated once a year for several hours at full load to clean the engine, in other words, to eliminate the carbonized oil deposits in the engine and exhaust system. This may require a reactive load. The load should be increased during the course of the four hours of the operation, from zero to full load.

If the failures mentioned above appear, along with long-term use of the generator with little energy load, operate the power generator at full load, if possible using a Resistive Load Bank before replacing any component.

7. INSTALLATION

Generator set installation should be performed by qualified personnel under observance of the regulations in the country where the installation is taking place.

7.1 GENERAL INSTRUCTIONS

To perform the installation, a number of general considerations should be taken into consideration, regardless of where the generator set is located. These considerations should be followed together with the specific recommendations for each installation, shown in Section 7.2 Outdoor installations and Section 7.3 Indoor installations, where appropriate. As a general rule, all elements that are physically connected to the generator must be flexible and have flexible connecting elements to absorb any vibrations generated, thus avoiding possible damage.

7.1.1 GENSET LOCATION

It is important to check that the doors of the generator set, in the case of soundproofed gensets can be opened completely, allowing access to materials for maintenance and inspections, so it is possible to completely remove the genset; and that the cooling system works properly.

The location of the generator set is very important, it is also necessary to take into account the proximity of the electrical switchboard, proper external fuel supply, the evacuation of exhaust fumes, disturbances caused by noise and exposure to exhaust fumes of other engines or airborne contaminants.

In general, the area where the generator set is installed must be duly closed off to prevent access to unauthorized persons. In the case of standard static gensets, in order to avoid unwanted contact with the machine operator, it is important to define a security area around the genset with a minimum distance of 2 meters of separation, leaving free access to both the control panel, and the emergency stop devices. At the same time, it is necessary to place appropriate entry prohibition and danger signs in visible areas.

NOTE

In the case of use in areas other than the reference environmental conditions, go to Section 6.3 Derating for operating environmental conditions.

7.1.2 FOUNDATIONS

The foundation must be calculated and sized by civil engineering specialists. The surface area where the generator is installed must be able to support a minimum of 150% of the weight of the equipment (where appropriate), together with the accessories and fluids, as well as keeping the assembly in a level horizontal position and in the most restrictive cases, prevent the transmission of vibrations to surrounding structures, taking into account that generator sets incorporate vibration isolators (anti-vibration elements) for this function.

To assess the need for the construction of foundations, it is necessary to take into account the genset's total wet weight, type (indoor or outdoor) and durability of the installation (provisional or stationary), restrictions related to the vibration, the type of soil and possible variations due to seasonal and climatic changes.

By way of example, in the event the use of concrete foundations is required, the depth that will support the weight of the equipment is obtained as follows:

$$H_{\text{foundation}} = \frac{W}{\rho_{\text{concrete}} \cdot L_{\text{foundation}} \cdot W_{\text{foundation}}}$$

Where:

- $H_{\text{foundation}}$ Height or depth of the foundation (m)
- W Total wet weight of the equipment (kg)
- ρ_{concrete} Density of the concrete (kg/m^3)
- $L_{\text{foundation}}$ Length of the foundation (m)
- $W_{\text{foundation}}$ Width of the foundation (m)

It is recommended that the dimensions of the foundation base exceed the dimensions of the base of the generator by at least 150 mm on all sides. In addition, to facilitate maintenance and service activities, we recommend raising the foundation above ground level by at least 100mm, as shown in the following foundation example:

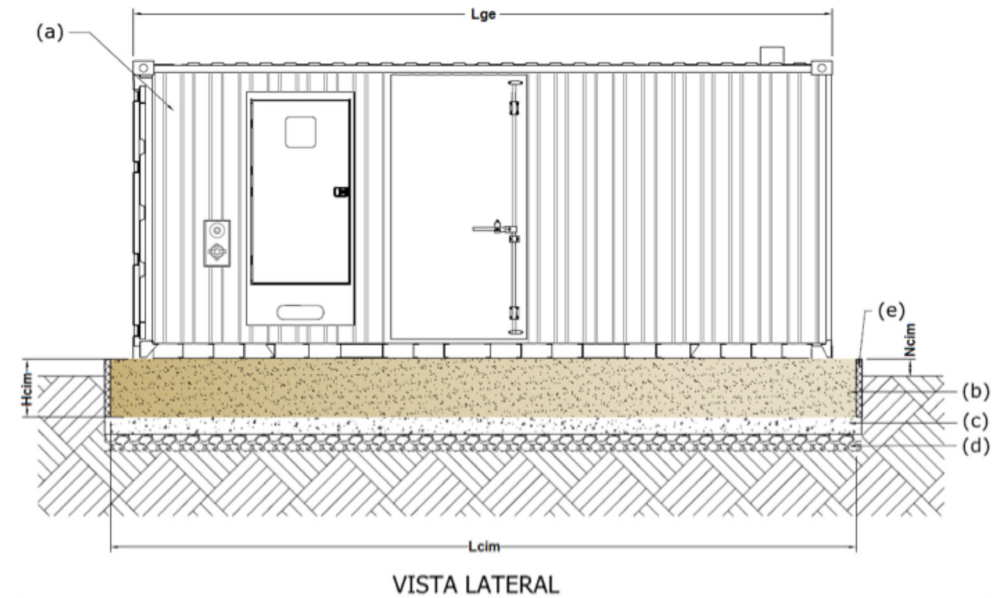

Where:

(a) Generator set in container	(d) Compacted stone paving
(b) Foundation slab	(e) Polyethylene or polyurethane insulation
(c) Underconcrete	

7.1.3 VENTILATION

Ventilation of the generator set plays a key role in the functioning and durability of the machine.

Inappropriate ventilation may cause excessive temperatures around the genset or inside soundproofed gensets, causing overheating and loss of efficiency in the operation of the genset components and therefore the genset in general.

Adequate ventilation must have the following characteristics:

- Allows emanated heat dissipation during operation of the genset by radiation and convection, introducing fresh, clean air and expulsing hot air from the radiator outlet.
- Ensures a sufficient volume of air to supply the flow required by the radiator and the proper flow of feed air, in the quantity necessary for combustion of the engine.
- Allows the engine to cool through the radiator and aftercooler, if included, keeping the ambient operating temperature of the generator set within safety margins, to ensure good feed air aspiration.
- Check that the direction of the prevailing wind is the same as the air flow in the genset, avoiding the possible recirculation of hot air.

The following principles should be taken into account:

- Heat from other sources should be considered in the design of the ventilation system.
- The genset's ventilation system is designed with all the doors closed, both in the case of the canopy and the premises.
- The generator set will be installed depending on the direction of the prevailing winds, whether indoors or outdoors.
- The altitude at which the genset is installed should be taken into account. As the altitude increases, air density decreases, requiring greater airflow than a genset operating at sea level.
- The temperature of the engine air intake is less than or equal to the ambient temperature.

The outlet must be located on the side shielded from the prevailing wind, to avoid reducing the outflow, while promoting the entry of fresh air into the generator set or room housing the genset. If this is not possible it will be necessary to use blocking walls, exterior ducting or deflector panel.

In the event details are required regarding the flow of air required for different types of HIMOINSA gensets, ask the factory for data.

7.1.4 EXHAUST SYSTEM

For the evacuation of exhaust fumes from the generator set, tubes are normally used made of smooth steel, seamless pipes, or, in special cases, with stainless steel pipes. The proper evacuation of exhaust fumes must be carefully considered since these fumes can be very harmful to health. They should be directed into the atmosphere through an open and preferably high place, away from windows, doors or vents and away from combustible materials or substances, where smoke, noise, odours and high temperatures do not cause discomfort or damage. Therefore, it is important to take into account as far as possible the prevailing winds to blow away the fumes from the buildings and areas likely to cause damage or discomfort to both individuals and to other machines, even the generator set itself. The genset can be supplied with flat caps in the exhaust system, to prevent possible damage to the system during transport of the genset.

In this case, once the genset has been installed, the flat caps will need to be replaced with exhaust system supplied with the genset, carrying out installation according to whether the genset is outdoors or indoors. For more information, go to Section 7.2 Outdoor installations. Exhaust system or to Section 7.3 Indoor installations. Exhaust system. It is important to perform this change, since keeping the exhaust system blocked can cause serious consequences for the machine and for people.

7.1.5 FUEL INSTALLATION

Generator sets include a fuel tank as standard which is installed inside the bedplate, and is supplied directly, with it only being necessary to control the fuel level according to the use given to the genset.

In some cases, for reasons of autonomy because of the use given to the genset or to minimize refuelling operations, the installation is provided with a separate larger reservoir with an electric pump, which maintains the fuel level in the tank of the genset or supply it directly. The location, materials, dimensions, components, installation, ventilation and inspection will be performed by the customer, who must comply with current regulations governing oil installations for own use in the country where the installation is to be carried out.

Therefore, you may want to install a fuel storage tank outside the genset, which always keeps the tank inside the genset at the necessary level for proper operation. To do this, upon request, the generator set incorporates a fuel transfer pump, it being necessary to connect the fuel supply line from the storage tank to the connection point of the genset.

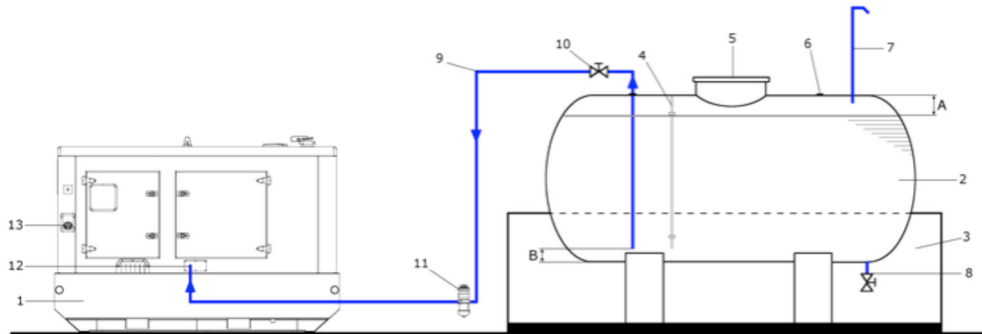

1. Internal supply tank	8. Drainage line
2. Storage tank	9. Supply line
3. Collection vat	10. Shutoff valve
4. Fuel level indicator	11. Fuel filter
5. Maintenance hatch	12. Fuel pump connection point*
6. Storage tank supply	13. Direct supply point
7. Vent line	

It is advisable to install the storage tank supply line as deep as possible, at a distance (B) not less than 5 cm from the bottom of the tank, thus avoiding the supply of air when the fuel level in the tank is low.

In turn, when filling the tank it is recommended that a clearance (A) of at least 5% is maintained to prevent spills due to fuel expansion caused by warming, always avoiding the penetration of dirt and/or moisture into the system.

It is recommended that the fuel storage tank is placed as close to the engine as possible, with a maximum of 20 metres of separation from the engine, with both at the same level. Consult the documentation of the fuel transfer pump for more detailed information on other possible configurations.

Another possibility may be to feed the generator set directly from an external storage and supply tank.

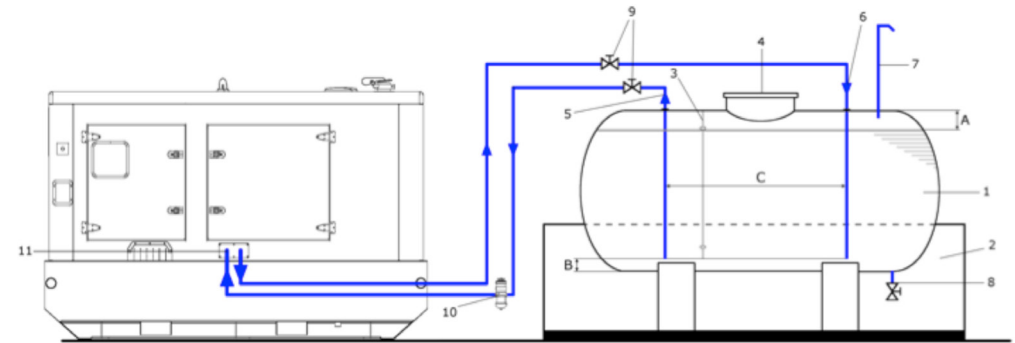

1. Storage and supply tank	7. Vent line
2. Collection vat	8. Drainage line
3. Fuel level indicator	9. Shutoff valves
4. Maintenance hatch	10. Fuel filter
5. Supply line	
6. Return line	11. Fuel connection point

It is advisable to maintain a separation between the supply line and the return line inside the tank to avoid overheating the fuel or allowing impurities to enter which may be detrimental to engine operation. The separation between the two lines (C) should be at the maximum possible, with a minimum of 50 cm, provided this is possible. The distance (B) between the fuel lines and tank bottom should be at low as possible, although not less than 5 cm. Similarly, when filling the tank it is recommended to keep a clearance (A) of at least 5% of the total capacity of the tank and position the fuel storage tank as close to the engine as possible, with a maximum of 20 metres of separation from the engine, with both at the same level. Ensure that the maximum level of fuel in the supply tank is below the height of the injectors. Consult the documentation of the fuel supply pump for more detailed information on other possible configurations.

In the case of separation which is greater than that specified in the documentation of the pump, installations at a different level to the generator set or due to the requirements of the regulations related to the installation of fuel tanks, the use of an intermediate tank between the genset and the main tank may be needed.

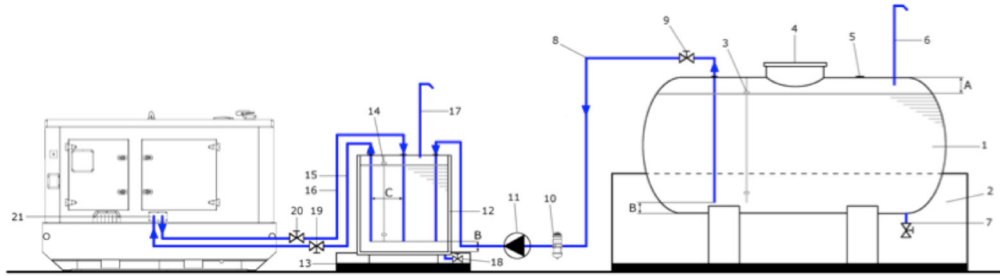

1. Storage tank	11. Fuel transfer pump
2. Fuel storage collection vat	12. Intermediate tank
3. Fuel level indicator	13. Intermediate tank collection vat
4. Maintenance hatch	14. Fuel level indicator
5. Storage tank supply	15. Generator set supply line
6. Storage tank vent line	16. Generator set return line
7. Storage tank drainage line	17. Intermediate tank vent line
8. Intermediate tank supply line	18. Intermediate tank drainage line
9. Intermediate tank supply shutoff valve	19. Genset supply shutoff valve
10. Fuel filter	20. Genset return shutoff valve
	21. Genset fuel connection point

The fuel transfer pump should be appropriate for the chosen location of the fuel storage tank; as well as the placement of the intermediate supply tank, the latter being in line with the specifications of the fuel pump inside the generator set.

As above, it is recommended that the supply and return lines inside the intermediate tank (C) be installed with greater separation, with a minimum of 50 cm, if possible. The distance (B) between the fuel lines and tank bottom shall not be less than 5 cm and a clearance (A) must be kept of at least 5% of the total tank capacity.

It is recommended that the fuel storage tank is placed as close to the engine as possible, with a maximum of 20 metres of separation from the engine, with both at the same level; ensuring that the maximum level of fuel in the supply tank is below the injectors. Consult the documentation of the fuel supply pump for more detailed information on other possible configurations.

It may be useful to install the tank at a slight angle (between 2° and 5°), placing the fuel supply line, drainage line and level meter at the lowest point.

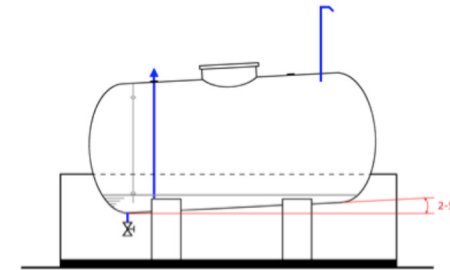

The design of the fuel system will be specific to the characteristics of the generator set installed and its components; having considered the quality, temperature, pressure and volume required of the fuel to be supplied as well as preventing the entry of air, water, dirt and moisture into the system.

NOTE:

With fuel installations for standard static gensets, the same instructions should be followed, connecting the fuel system directly to the appropriate components (transfer pump, internal tank, etc.).

Fuel storage is essential for the proper functioning of the generator set. It is therefore advisable to use clean tanks for the storage and transfer of fuel, periodically emptying the tank to drain the decanted water and sediments on the bottom, avoiding long periods of storage and controlling the fuel temperature as excessive temperature increases may reduce fuel density and lubricity, reducing the maximum power output.

NOTE:

The average service life of good quality diesel is 1.5 to 2 years, provided proper storage is always carried out.

Avoid excessive heating of the fuel lines, both supply and return, as this could be harmful due to the formation of vapour bubbles that will affect engine ignition. The pipes shall be made of seamless black iron, avoiding galvanized steel, copper, cast iron and aluminium, as these materials can be problematic for fuel storage and/or supply.

Flexible connections have to be used with the combustion engine to isolate the fixed parts of the installation from any possible induced vibrations. Depending on the characteristics of the combustion engine, these flexible lines can be carried out by:

- Sections, of suitable length, of reinforced rubber pipes with flexible inserts which are resistant to diesel oil using tubing connections with edges and closed with screw clamps for connections to the terminal.
- Low pressure type flexible pipes, suitable for diesel oil, protected by wire mesh and screw terminals for sealing.

In addition, the design of the fuel line must take into account:

- The piping must be fixed by means of brackets at regular intervals so that the vibrations and inflections caused by the weight of piping are avoided. Consider positioning the installation in low conduits in the vicinity of the genset.
- Avoid, as far as possible, creating pipeline connections. In the event they need to be carried out, they must be sealable, especially in parts which are subject to depression (fuel suction inlet), to prevent air infiltration which can make it more difficult to start.
- The suction pipelines under the fuel level should be at least 5 cm from the bottom, and suitably distanced from the fuel return pipeline to avoid the possible suction of impurities in the diesel oil at the bottom of the tank; guaranteeing an air-free fuel supply at all times.
- Avoid sharp changes in the direction of the piping using elbows with large curvature radii.
- Avoid having transit areas close to the components of the exhaust system, heating pipes or electrical wiring.
- It is recommended to have shut-off valves at appropriate points to allow thorough cleaning, repair or replacement of pipes without the need to empty the entire system. Keep in mind that operating the engine with the supply or return line closed may cause serious damage.

NOTE

It is important to consult, and follow, with particular attention the provisions set out in regulations related to the installation of fuel systems, given that in some countries fuel is classified as a “dangerous product”. Also, it is important to consult the technical specifications of the installation components included in the genset, following its assumptions.

7.1.6 ELECTRICAL CONNECTIONS

The gensets are designed to be connected to users. Upon connection, it is necessary to respect the conditions indicated in the diagrams that are supplied with the genset.

The selection and sizing of the cables is the responsibility of the installer that carries out the installation, depending on the type of cable and the regulations that apply in the country in which the installation is taking place.

The power cables must be connected to the line terminals situated at the lower part of the electrical panel, which must be located on appropriate protective conduits, tunnels or conductor bearing cubicles. It is recommended to separate cables with different voltages, respecting a minimum distance between layers of 25 cm, always placing the cables with the highest voltage in the deepest area, thus avoiding possible magnetic interference.

7.1.7 EARTHING

The metal parts of the installations which are exposed to contact with people, because of an insulation fault or other accidental causes, could become live. To ensure the protection of people, the electric installation and the equipment, the customer must earth the generator set.

To carry out the earthing, the generator sets contain a main earthing terminal located inside the container, and additional earthing points, usually in the corners of the bedplate and inside the panel, if included. The customer must connect their earthing rod to the genset's earthing installation via an insulated copper conductor with a minimum section of 16 mm² or with a bare copper conductor with a minimum section of 25 mm².

The materials, dimensions and depth of the earthing rod should be chosen so as to withstand corrosion and have appropriate mechanical strength. It should be installed vertically into the ground. The resistance of the earthing rod depends on its size, its shape and the resistivity of the soil in which it is embedded. This resistivity usually varies from one place to another, and varies according to the depth.

The choice and dimensioning of the conductors and earthing rod will be the responsibility of the installer performing the installation and must take into account relative local and national regulations.

7.2 OUTDOOR INSTALLATIONS

After consulting the general installation instructions, shown in the previous paragraph and the relevant regulations, in the case of installing the generator set outside particular attention should be given to the noise generated, to the environmental conditions, the exhaust fumes and the influence of seasonal and meteorological changes on soil characteristics and the environment.

In cold environments, the starting time and charge acceptance could be affected. It is advisable to include auxiliary heating devices for coolant, fuel or oil.

7.2.1 GENSET LOCATION

We recommend positioning the generator set in a location which is as isolated as possible, avoiding locking the doors of the canopy or container and ensuring there are no elements that may hinder the entry and exit of air.

Choose a location with adequate ventilation and in areas not prone to flooding during storms or the accumulation of snow, also avoiding other heat sources from being located close to the genset (boilers, other engines...).

Protect the genset from exposure to airborne contaminants such as vapours, engine exhaust fumes, abrasive or conductive dust, oil mist, smoke, lint and other contaminants.

Avoid the transit areas of motor vehicles or forklift trucks and prevent possible impacts from falling objects like trees or poles.

STANDARD STATIC GENSET

This type of generator set is not designed for outdoor use. However you could study operation while sheltered under a basic structure, whereby the genset would be protected from rain, snow and sun, conditioning the exhaust pipes to prevent the accumulation of gases.

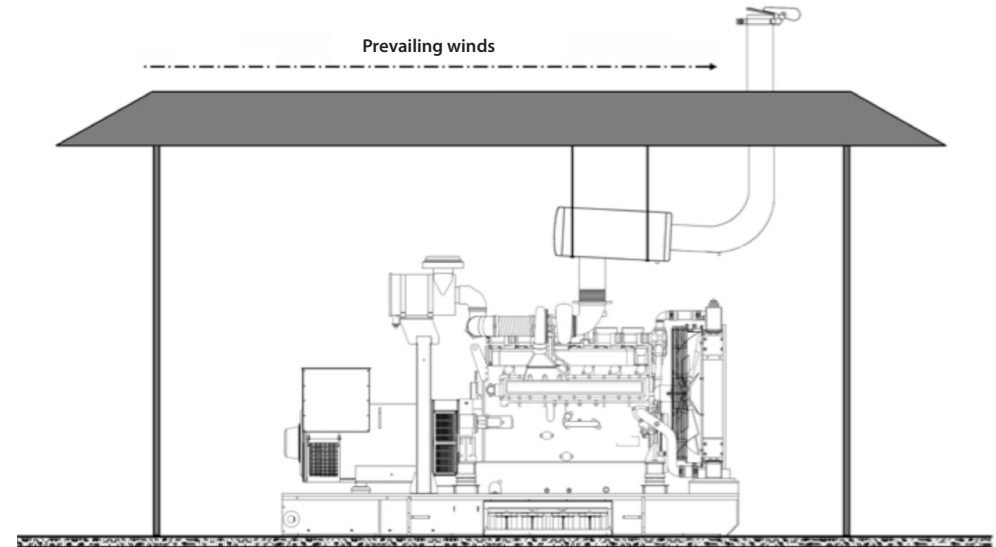

However this solution could affect machine operation due to airborne contaminants, increased noise due to reverberation caused by the structure or improper venting, among other factors.

Therefore for outdoor installations we recommend using static gensets which are soundproofed or in a container, designed and protected for use outdoors.

SOUNDPROOFED STATIC GENSET

Designed for use outside, these generator sets require no special protection for outdoor installation. The only requirement is that the necessary space be kept free so that all the genset doors can be opened and maintenance tasks can be performed without difficulty.

7.2.2 VENTILATION

Provided the necessary genset separation margins are respected as detailed above, the ventilation system will operate as established with sufficient air flow in and out.

It is important that the genset is suitably positioned to ensure the entry of dry, clean, cool (ambient temperature) air and with the proper flow; and in turn, prevent exhaust fumes from being channelled towards the genset's air inlet. The outlet must be located on the side shielded from the prevailing wind, to avoid reducing the outflow. If this is not possible it will be necessary to use blocking walls, exterior ducting or deflector panel.

In the event wind and noise barriers need to be installed, follow the recommendations given in Section 7.3 Indoor installations. Ventilation.

7.2.3 EXHAUST SYSTEM

Check the direction of the prevailing wind and ensure that exhaust fumes do not pose a danger, especially in windy conditions, avoiding any discomfort or damage.

In the event the genset is supplied with flat caps on the exhaust system, once the genset has been installed these flat caps will have to be replaced with tilting exhaust caps, which will be delivered with the generator set.



NOTE

To make changes or add items to the exhaust system, refer to the specifications detailed in Section 7.3 Indoor installations. Exhaust system.

7.3 INDOOR INSTALLATIONS

After consulting the assumptions shown in Section 8.1 General information and the relevant regulations, in the case of installing the generator set indoors particular attention should be taken with the ventilation system and the evacuation of exhaust fumes.

NOTE

It is possible that by installing the genset in a closed enclosure the sound pressure level will increase with respect to the established value, due to echoes or reverberations generated with the walls. After installation the user should perform acoustic measurements to determine the sound pressure level under conditions of 75% of the prime load, and if necessary implement appropriate preventive measures. It might be good idea to consider installing noise reduction systems, such as double walls in the room, soundproofing materials in the walls, silencers, etc.

7.3.1 GENSET INSTALLATION ROOM

It is recommended that the room where the genset is installed be used exclusively for the operation of this equipment, together with electrical panels, transfer switches or other generator sets, isolated from other rooms. It must be possible to introduce the genset into this room with the means of transport available, being centred with respect to the access door in the case of one genset, positioned in the middle of the room without having to move it inside, if possible. It is necessary to ensure there is adequate lighting which will allow all operations to be performed safely.

The separation distance of the genset, both on the two sides of the genset and the rear of the genset (alternator zone) with respect to the walls of the room should be at least 1 metre for gensets with power less than 300 kW, or 1.5 metres for gensets with higher power than 300 kW. For soundproof gensets, the separation distance may be greater because it is necessary to allow space for the complete opening of the doors. However, it is advisable to leave the largest possible free space around the genset to facilitate maintenance, also increasing the safety distance between operators and the machine.

It is advisable to place the generator set on the ground floor of a building or in a room at the level of the ground outside, allowing transport, maintenance, repairs and replacements to be carried out easily.

NOTE

In the case of installing multiple generator sets, the instructions to be followed are the same. The installation of each of the gensets will be carried out following the instructions shown in this manual.

The following figures show the recommended layout of the room housing the generator set, depending on the construction version in question, where:

a. Generator set	f. Reinforced concrete base
b. Access door	g. Exhaust pipe
c. Air inlet	h. Flexible coupling
d. Flexible air expulsion tunnel	i. Exhaust silencer
e. Grommet tray	j. Dimensions of the generator set

STANDARD STATIC GENSET

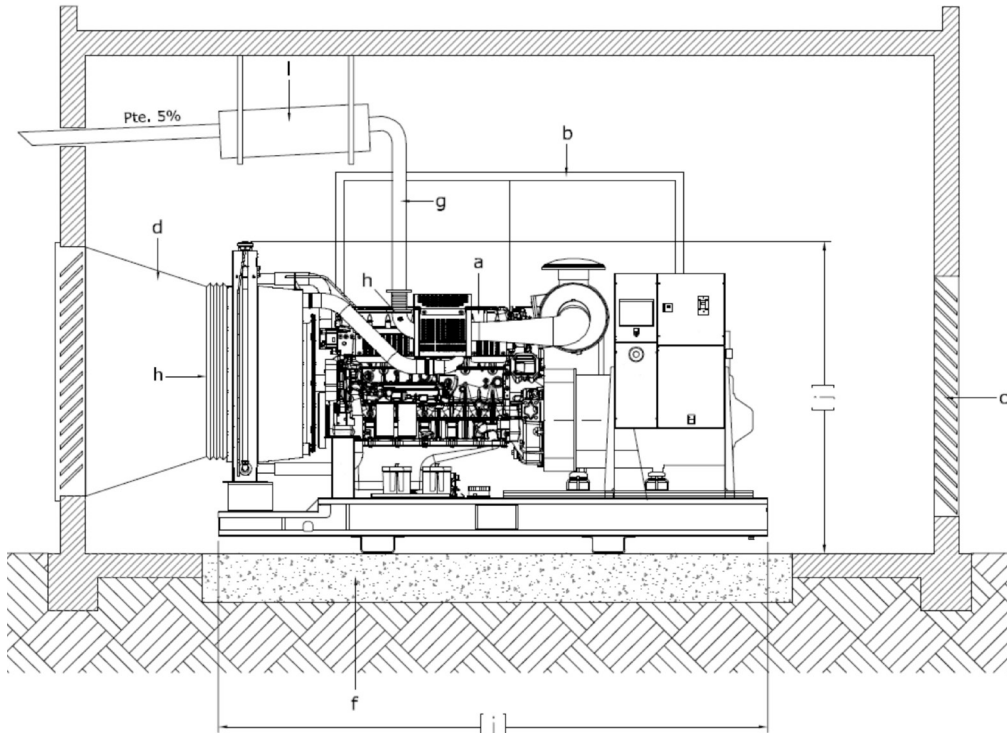

SIDE SECTION VIEW

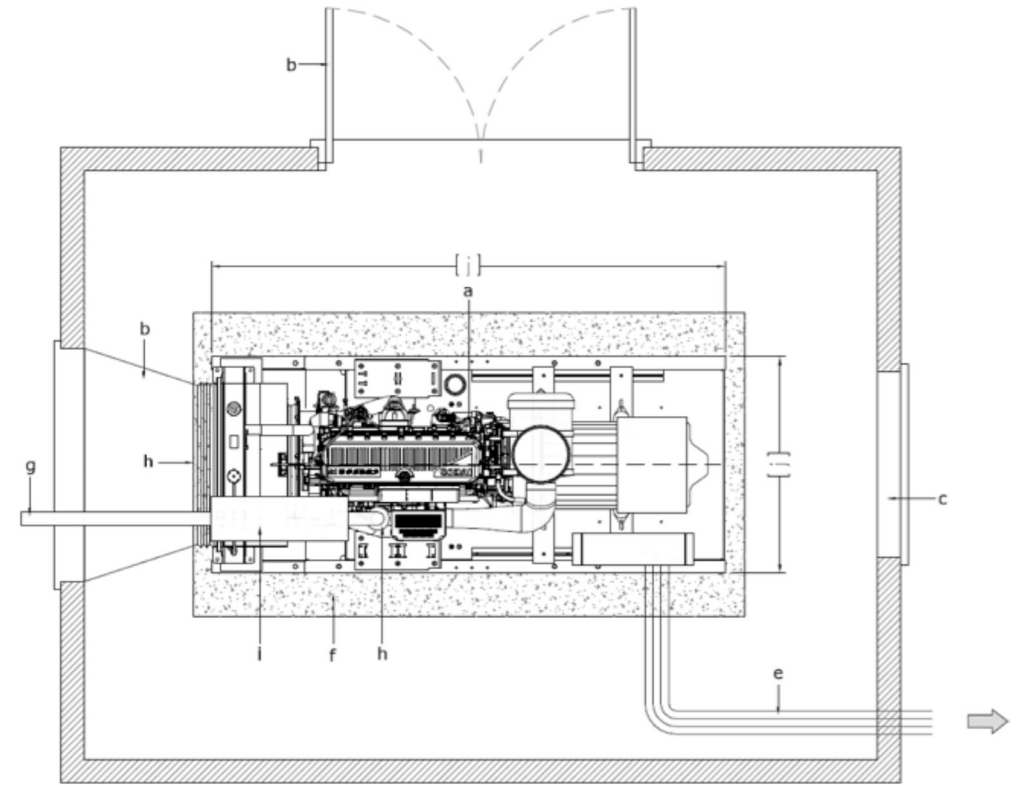

TOP VIEW

SOUNDPROOFED STATIC GENSET/IN CONTAINER

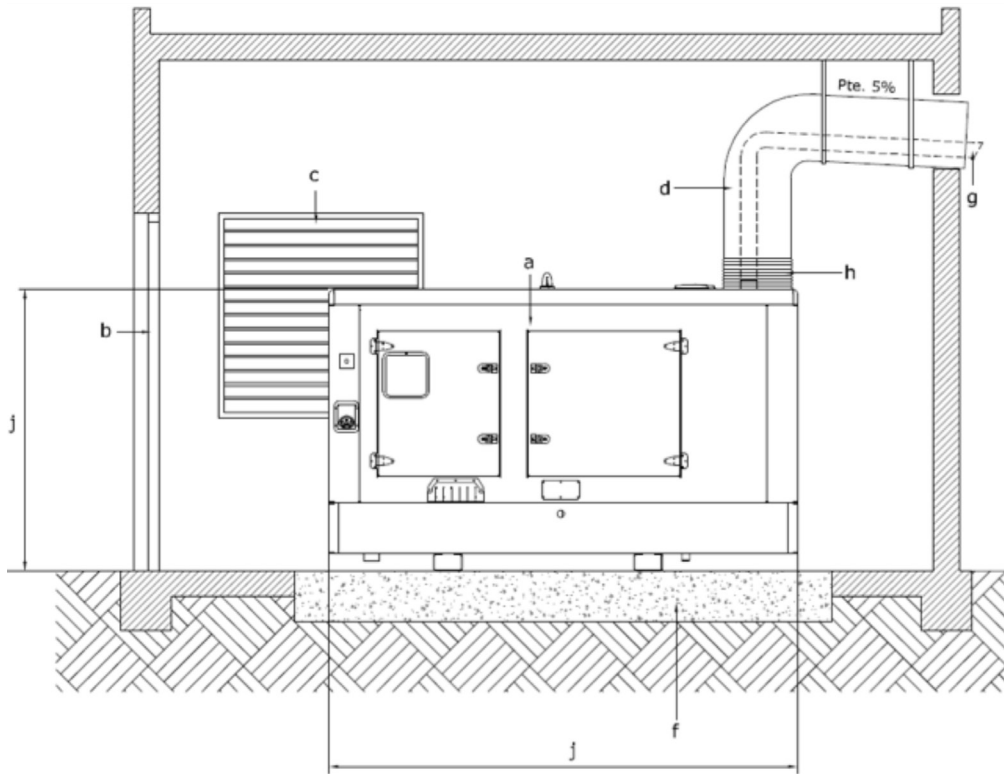

SIDE SECTION VIEW

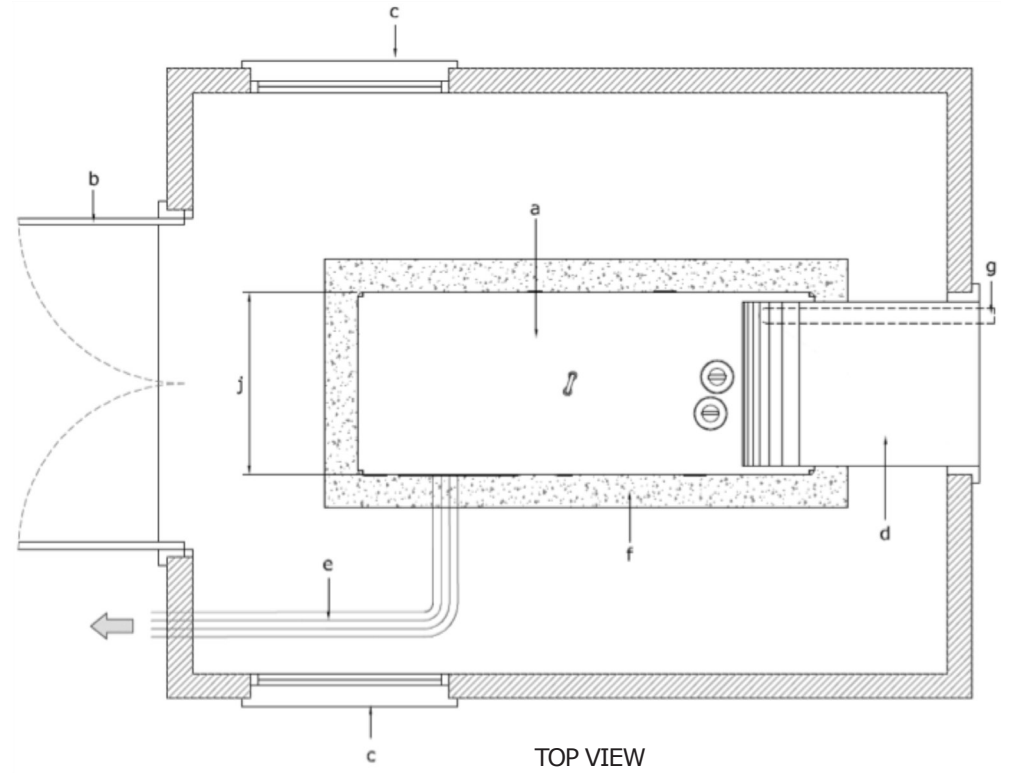

TOP VIEW

7.3.2 VENTILATION

The air inlet and outlet allow air circulation throughout the generator assembly, from the alternator end to the radiator end, following the direction of the alternator, the engine and last the radiator.

Ventilation air must be clean and fresh, taken directly from outside, and also discharged outside, preventing it from mixing with water as far as possible, with the installation of rainproof awnings or covers an option.

Regarding the position of the air inlet and outlet holes, this will depend directly on the ventilation in the room where it will be installed, with optimum ventilation incorporating an air entry hole and another for air expulsion.

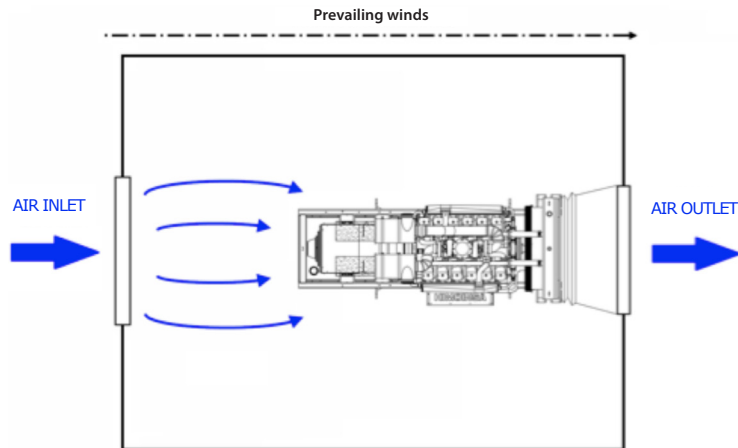

It might also be a good idea to consider installing extra air intake holes, ensuring the inflow of air reaches and cools all the components of the generator set.

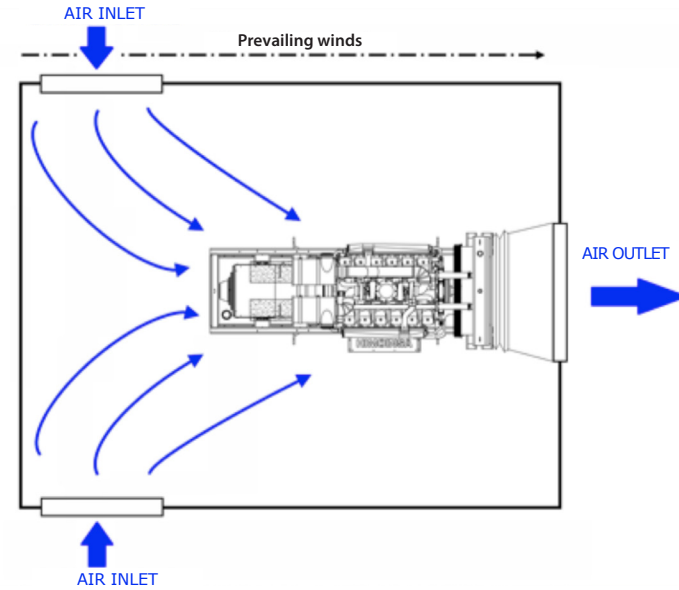

Where it is not possible to influence the inflow of air reaching all the components of the genset or in the event the air intake holes are in a higher position, a deflector must be placed to channel the inflow directly towards the genset, reaching all the components. In this case, ensure that this does not result in load losses exceeding the maximum permissible levels indicated in the genset data sheet.

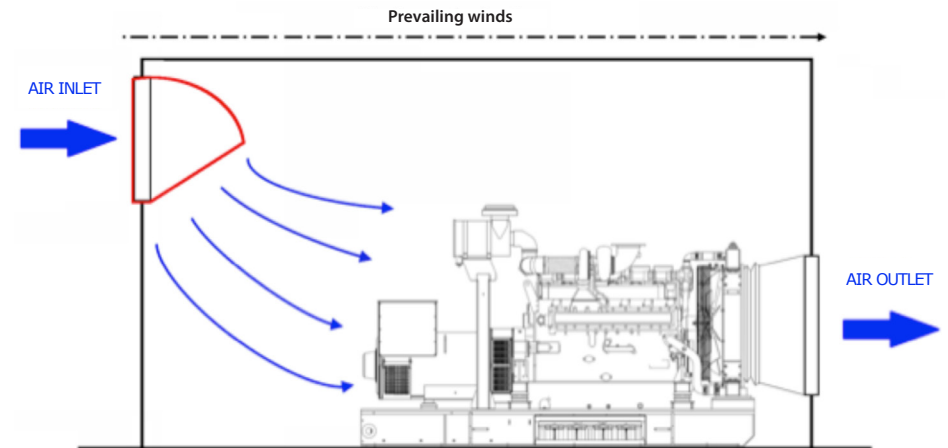

For soundproofed gensets, it is recommended that the inflow of air is aimed directly towards the air intake holes on the canopy, therefore making sure the distribution of holes in the room is prepared according to the genset canopy.

The air inlet openings and air outlet openings for standard static gensets should have a free flow area that is at least 25% larger than the front panel area of the radiator, except where the inlet and outlet are tubulated with elbows, being at least 50% larger. It is recommended to slightly increase (+ 5%) the air intake area of the room, once calculated.

In the case of soundproofed gensets, the air inlet area must be at least equal to the sum of the area of all the air inlet openings incorporated on the canopy or container. The outlet area is obtained in the same way as with standard static gensets, 25% larger than the radiator area.

It is very common to include grids in the air inlet and outlet holes, where the total area does not match the effective or free area, which would be the area required for proper ventilation. Please contact the manufacturer of the grids with regards the effective or free area and the inclination of these grids, because including them will increase the total area of the holes to be installed in the room. By way of example, a calculation method is indicated below:

EXAMPLE: STANDARD STATIC GENSET

Frontal panel area of the radiator: 1 m² (1 m x 1 m)

The air input/output should be 1.25 m² (1.118 m x 1.118 m), but if grids are installed with a free or effective area of 85%, the input or output area will be 1.471 m² (1.213 m x 1.213 m).



In the event these grids are inclined at an angle of 35°, the final height required for the air inlet and outlet holes is obtained as follows:

$$H_{\text{final}} = \frac{H'}{\cos 35^\circ} = \frac{1.213}{\cos 35^\circ} = 1.481 \text{ m}$$

Finally resulting, for the given conditions, with an area of **1.796 m²** (1.213m x 1.481m).

Once the area needed to ventilate the generator has been calculated, it is possible to install as many air intake holes as you want, as long as the sum of all areas is at least equal to the required area calculated.

Once intake and expulsion of air holes have been installed, ensure that the air intake speed is not very high, to prevent rain or snow entering the room, using the following expression:

$$A = \frac{\dot{m}}{v}$$

Where:

A: Effective or free flow area (m²)

m: Volumetric flow rate (m³/s), corresponding to the air necessary for combustion together with the air necessary to cool the room compensating for the heat radiated by the genset components

v: Air flow rate (m/s)

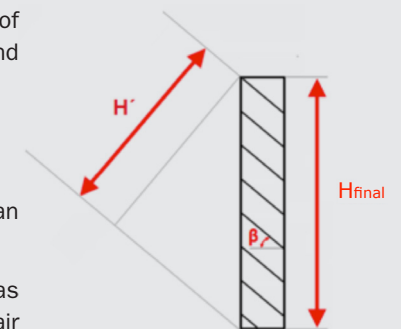

It is advisable that the flow rate into the air intake hole does not exceed 2.5 to 3.7 metres/second. To obtain high speeds, the areas must be increased so that they fall within the recommended range.

With regards the air expulsion hole, we recommend installing a duct connecting the radiator outlet with the air expulsion hole using a flexible connection, which is as short as possible, thus avoiding the possible return of hot air into the room. It is important to prevent the hot air expelled through the extraction tunnel from re-entering the engine room, taking care that the ducts which discharge this air are sealed. In this way, the air is constantly renewed in the engine room environment, as the dimensions of the intake openings are sufficient for cooling and combustion.

For soundproofed gensets, since they are designed for outdoor locations, air expulsion through a duct may present some difficulties due to the exhaust pipeline and the curve or elbow which would need to be installed to evacuate air outside the room. Because of this, it is possible to remove the front canopy panel next to the radiator, to attach the air outlet duct easily and with greater efficiency, with it being necessary to plug the air outlet on the canopy to ensure proper ventilation of the generator set.

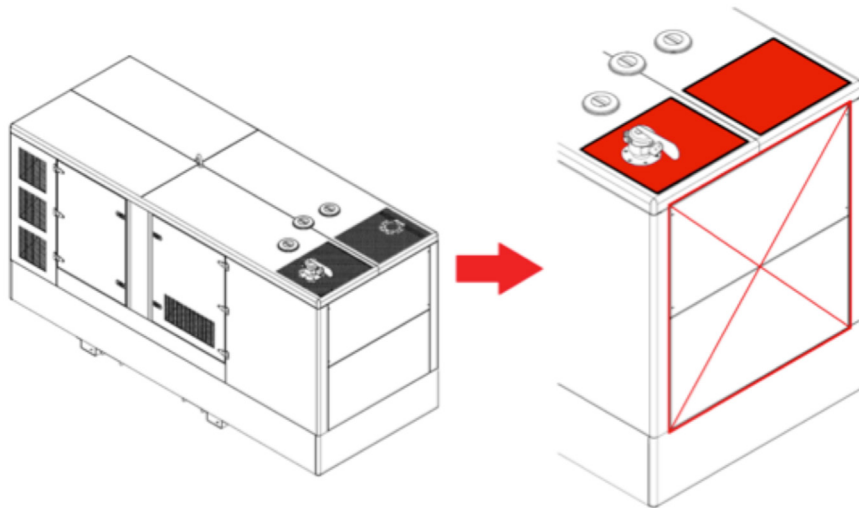

The outlet must be located on the side of the building shielded from the prevailing wind, to avoid reducing the outflow. If this is not possible it will be necessary to use blocking walls, exterior ducting or deflector panel.

In the case of installing a wind and sound barrier, it is recommended to leave a distance between this and the air outlet of the room, of approximately 3 times the height of the radiator, and never less than the height of the latter.

In restricted areas, it is advisable to install a deviation deflector including water drainage, to guide the hot air flow in turn preventing the entry of water.

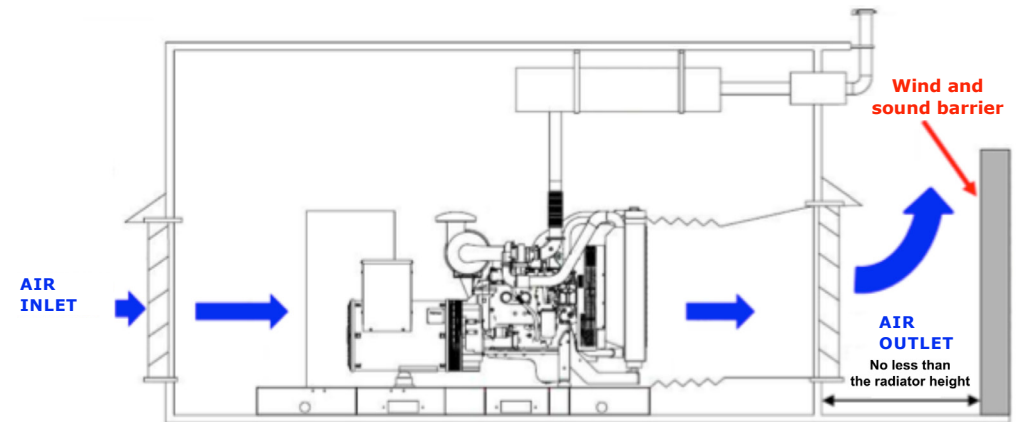

It is important to ensure there are no areas in the engine room where the air stagnates. This happens more frequently in premises with several engines, in this case, and as far as possible, each genset engine should have its own air intake opening.

It might be good idea to consider, in the case of room temperatures in excess of those permitted by the electronic components of the genset (60°C), using a remote fan to help cool the room; and in the case of temperatures below the permissible minimum, it might be good idea to consider a partial recirculation of hot air at the radiator outlet.

7.3.3 EXHAUST SYSTEM

It is advisable, whenever possible, for the pipes to be arranged vertically and incorporate a tilting cap on the exhaust outlet, which remains open when the genset is running due to the pressure of the exhaust fumes and is closed when there is no flow of exhaust fumes, thus preventing water from entering the exhaust system.

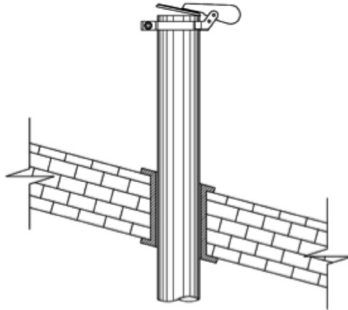

In the event that the exhaust outlet has to be installed on the side of the room, it can be installed with a tilting cap with seamless 90° elbow, separated by a minimum distance of 10 cm from the wall it passes through and with a distance from the ground of at least 220 cm.

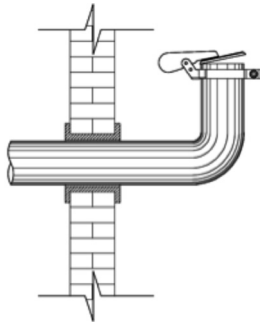

At the point where the exhaust system passes through the walls, it is a good idea to provide the pipes with heat insulation, to prevent heat dispersion into the walls.

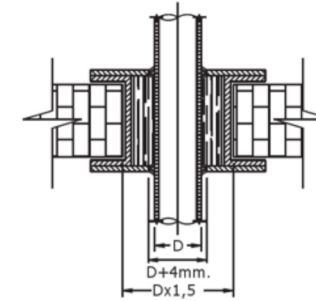

The connections between the various stretches of the pipeline must be perfectly sealed, so that there are no leakages of fumes. Connections with a flange and gasket are the most suitable. In addition, we recommend installing the horizontal sections at a slight angle (5°), with a condensation discharge positioned at the lowest point of the piping (lower elbows and/or points of the sloping sections) to prevent the possible accumulation of exhaust fume condensate.

The connection between the engine exhaust manifold outlet (or turbo blower exhaust for the supercharged systems) and the pipelines should be through a vertical flexible tube section, so that the actions induced by the engine, and the thermal expansion of the piping, will be absorbed by it, without damaging any elements.

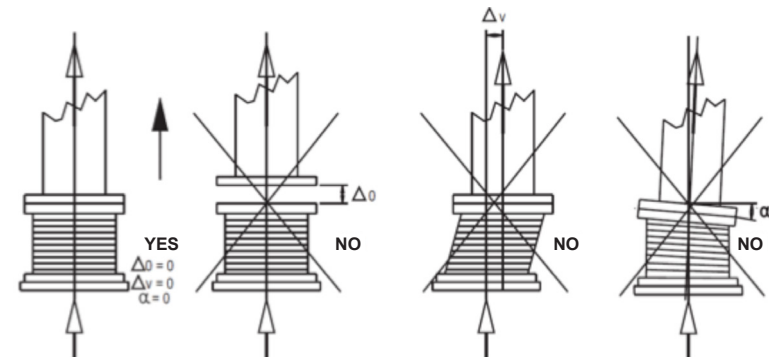

The use of the flexible element also requires the placement of flanges on the exhaust piping, regardless of the generator set. As a result the pipes are fixed to the walls or ceiling of the engine room with supporting brackets which can withstand the full weight of the piping to the engine outlet so that it rests on the engine parts (collector, turbo blower) and allows expansion to occur.

When dealing with very long pipes, it is necessary to insert, at intervals, expansion joints made with watertight flexible elements, and the pipes must be also be installed with a slight slope, with a condensation discharge positioned at the lowest point.

When establishing the path of the exhaust piping, it is important that it is not in the vicinity of the engine air filters to prevent the machine from intaking hot air, or any other component that could be affected by a temperature rise. Otherwise, it will be necessary to thermally insulate the piping.

When installing a silencer on the exhaust system, it should be positioned as close as possible to the exhaust outlet of the combustion engine and must be positioned horizontally. On the following pages there is more detailed information about the installation of silencers on the exhaust system.

When dealing with several gensets, it is advisable not to converge all the exhaust outlets on one pipeline because problems may occur when one or more gensets are functioning and others are not. Exhaust fumes produced by the gensets can penetrate into the ducts of stopped machines and cause damage.

SIZING EXHAUST PIPES ON STANDARD STATIC GENSETS

The difference between the average pressure in the exhaust pipe and the atmospheric pressure is called backpressure in the exhaust system, which has a significant influence on the power delivered by the engine and the heat load. The backpressure value is a measure of resistance to the free flow of fumes through the various components of the exhaust system.

Backpressure values cause excessive power reductions, increases in temperature of the exhaust fumes, smoke, high fuel consumption, overheating of the cooling water, lubricant degradation and the corresponding impact on engine parts.

Backpressure measurements will always be taken downstream of the exhaust system, particularly in the exhaust manifold outlet to naturally aspirated engines or the turbine outlet in the case of supercharged engines, provided in straight sections, avoiding problem areas such as section changes or curves.

The backpressure obtained in the exhaust system must always be below the maximum recommended in the technical specifications of the combustion engine based on the power conditions and maximum delivery rate.

This limitation can be respected by implementing dimensions and distribution which is adapted to the exhaust, taking into account the influence of the silencer type.

CALCULATION OF EXHAUST SYSTEM BACKPRESSURE

The diameter of the exhaust system must be greater or equal to the diameter of the exhaust outlet of the generator set, which will be the starting point of the exhaust system installed.

The pipelines must be as short as possible, and with as few elbows as possible. When these are indispensable, they must be made seamless and with a very large curvature radius (2.5 to 3 times the diameter of the pipe). Solutions with a smaller radius of curvature of 2.5 times the diameter, present difficulties and as such must be avoided.

The total backpressure of the exhaust system is the sum of the backpressure generated in the elements which compose the exhaust system:

$$\Delta P_{\text{total}} = \Delta P_{\text{piping}} + \Delta P_{\text{outlet}} + \Delta P_{\text{silencer}}$$

BACKPRESSURE IN THE EXHAUST PIPING ΔP_{PIPING}

The expression to obtain the pressure in the exhaust pipe is as follows:

$$\Delta P_{\text{pipeline}} = \frac{6.32 \cdot Q^2}{T + 273} \cdot \sum \left(\frac{L_{\text{eq}}}{D^5} \right)_{\text{sections}}$$

Where:

ΔP : Backpressure through the exhaust pipe (Pa).

Q: Volumetric flow of the exhaust fumes (m³/s), indicated in the generator set data sheet.

T: Temperature of exhaust fumes (°C), indicated in the generator set data sheet.

D: Internal diameter of each pipe section (m).

L_{eq} : Equivalent length of each pipe section (m), depending on the element installed.

STRAIGHT SECTION

The equivalent length of a straight section will be directly the total length of the straight sections with the same diameter.

In the case of straight sections with different pipe diameters, it is recommended to separate the equivalent lengths avoiding errors when calculating the backpressure since each will be associated with the piping diameter.



ELBOW OR CURVE 90°

The equivalent length for a 90° elbow without welds will depend on the piping diameter (D) and the curvature radius (R), both in metres.

	D ≤ 0.065	D < 0.1	D < 0.2	D < 0.3	D ≥ 0.3
R ≤ 1.3D	30D	40D		55D	70D
R ≤ 3D	15D		18D	23D	30D
R ≤ 5D	14D			17D	21D
R > 5D	7D			14D	

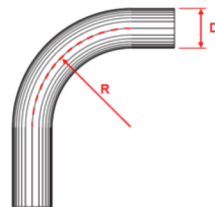

ELBOW OR CURVE 45°

The equivalent length for a 45° elbow without welds will also depend on the piping diameter (D) and the curvature radius (R), both in metres.

	D < 0.2	D ≥ 0.2
R < 1.3D	15D	25D
R ≥ 1.3D	7D	14D

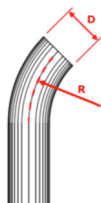

ELBOW OR CURVE 90° (WELDED SECTIONS)

The equivalent length for a 90° elbow with welds only depends on the piping diameter (D) in metres.

R < 0.1D	D < 0.2	D ≥ 0.2
30D	45D	60D

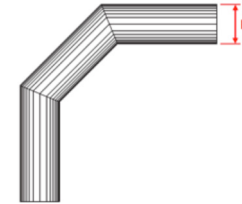

ELBOW OR CURVE 45° (WELDED SECTIONS)

The equivalent length for a 45° elbow without welds will also depend on the piping diameter (D) and the curvature radius (R), both in metres.

D < 0.2	D ≥ 0.2
30D	50D

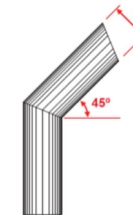

FLEXIBLE COUPLING OR EXHAUST COMPENSATOR

The equivalent length is 1.7 times the length of the compensator ($L_{\text{compensator}}$). Attention should be paid to calculate the pressure in this section, using the diameter of the compensator ($D_{\text{compensator}}$).

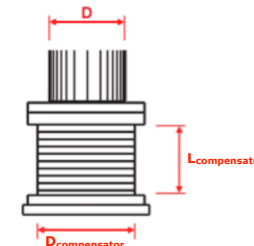

SECTION JUNCTION ENLARGER

The equivalent length is directly the length of the enlarger (L_{enlarger}). It is important to calculate the backpressure in this section, using the average diameter of the section change.

$$D = \frac{D_1 + D_2}{2}$$

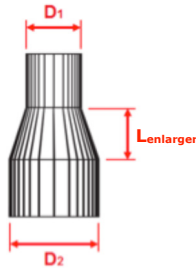

7.3.4 BACKPRESSURE AT THE OUTDOOR EXHAUST FUMES OUTLET (Δ_{OUTLET})

This is the backpressure generated by the pressure difference upon expulsion from the exhaust pipeline into the open air. In the case of installing a tilting cap, consider backpressure of 40 mmH₂O.

7.3.5 BACKPRESSURE IN THE EXHAUST SILENCER (Δ_{SILENCER})

In the event that the genset incorporates a HIMOINSA silencer, consult the HIMOINSA Technical Department regarding the backpressure value.

In the event that the customer wants a particular silencer installed, consult the manufacturer or supplier regarding the specific value or the method of calculating the backpressure. If these options are not possible, an estimated value of backpressure can be obtained using the general calculation method.

GENERAL CALCULATION METHOD OF BACKPRESSURE IN THE EXHAUST SILENCER

The backpressure (mmH₂O) will depend on the type of exhaust used and the speed of the exhaust fumes in the silencer (m/s).

$$V_{\text{ges}} = \frac{Q}{A_{\text{ent}}}$$

Where:

V_{ges} : Speed of the exhaust fumes in the silencer (m/s)

Q : Volumetric flow of the exhaust fumes (m³/s), indicated in the generator set data sheet

A_{ent} : Silencer inlet area (m²), where the inlet diameter of the silencer is known ($A_{\text{ent}} = \pi \cdot D_{\text{ent}}^2 / 4$)

INDUSTRIAL GRADE SILENCER

$V_{\text{ges}} \leq 25.42$	$V_{\text{ges}} \leq 50.8$	$V_{\text{ges}} > 50.8$
2.36 V_{ges}	5.2 $V_{\text{ges}} - 71.22$	9.23 $V_{\text{ges}} - 275.84$

RESIDENTIAL GRADE SILENCER

$V_{\text{ges}} \leq 17.79$	$V_{\text{ges}} \leq 47.75$	$V_{\text{ges}} > 47.75$
2 V_{ges}	7.54 $V_{\text{ges}} - 98.58$	10.29 $V_{\text{ges}} - 224.39$

CRITICAL GRADE SILENCER

$V_{\text{ges}} \leq 25.42$	$V_{\text{ges}} \leq 50.8$	$V_{\text{ges}} > 50.8$
4.81 $V_{\text{ges}} - 18.08$	9.91 $V_{\text{ges}} - 147.77$	17.96 $V_{\text{ges}} - 556.77$

The exhaust system backpressure must be kept in the same units as the rest of the exhaust system backpressures:

$$1 \text{ mmH}_2\text{O} = 9.8064 \text{ Pa}$$

Finally, once the backpressure is calculated which is generated in each of the elements that compose the exhaust system, it is necessary to check that this value does not exceed the backpressure limit indicated by the engine manufacturer, which can be obtained in the combustion engine documentation. Both values in the same units of pressure.

$$\Delta P_{\text{total}} \leq \Delta P_{\text{max}}$$

In the event this condition is not met, increase the diameter of the pipeline until the backpressure does not exceed the maximum allowed in the engine.

SIZING EXHAUST PIPES ON SOUNDPROOFED STATIC GENSETS

Contact the HIMOINSA Engineering Department. At the outlet of soundproofed gensets there is backpressure due to the piping installed inside. It is necessary to know this value so as not to exceed the recommended backpressure when designing the rest of the installation.

7.3.6 HEATING

In the case of automatic operation gensets, the engine room in which they are installed must be suitably equipped for the cold season so that the room temperature does not fall below 10-15 °C, a necessary condition for quick starting of the engine.

These gensets are also provided with electric heaters with thermostatic control from 500 to 5000 W, depending on the type of genset, which maintain the water temperature at acceptable values for unexpected starting and a charging outlet, and which do not cause problems for the engine.

8. USING THE GENERATOR SET

8.1 CHECKS PRIOR TO STARTING

These operations must be performed in the following situations:

- Before commissioning
- After installation of the genset
- After a comprehensive revision
- After maintenance operations
- After a long period of inactivity

IMPORTANT

During these operations, ensure that the genset cannot start unintentionally, that it is locked and the starter batteries are disconnected.

8.1.1 EXHAUST SYSTEM

Check the correct installation of the tilting caps on the exhaust system, ensuring they are correct attached and move properly.

8.1.2 RADIATOR WATER LEVEL

When there is insufficient water, it must be replaced with a mixture containing a maximum of 50% glycol, as antifreeze solution or corrosion inhibitor, and the rest clean water. Consult the engine documentation to find out the precise coolant composition recommended.

8.1.3 LUBRICATING OIL LEVEL IN THE TANK

Checks must be carried out to ensure there is a sufficient oil level for proper operation of the generator set, both in the engine crankcase, by viewing the oil dipstick, and oil tank, if present.

The type of oil to be used is specified in the generator set's data sheet. For other types of oil, refer to the engine manual.

8.1.4 FUEL SUPPLY

Check that the operating conditions of the combustion engine are met with regards fuel, the absence of losses in the fuel installation and the resistance and sealing testing.

Check the fuel level in the tank, always ensuring it is at the necessary level for the use which will be given to the generator set.

Check that the fuel filters do not contain water or particles.

If the generator set includes the three-way valve option, carry out the following check before the start-up:

- Check that the fuel inlet and outlet hoses from the external tank are properly connected to the quick connections of the three-way valve.
- Check that the lever is always fully engaged (i.e. either at the internal or the external tank position), never at the middle position.



CAUTION

DO NOT start up the genset with the handle of the three-way valve set at the external tank position and NOT connected. Otherwise excess pressure will build up in the fuel return line, which may damage the engine.

If these instructions are not followed, any costs will be to the account of the customer.

8.1.5 ELECTRICAL RULES

Before starting up the genset, check the electrical connections, starter batteries and earthing. The cable connections should be well tightened and free of corrosion. Open all the switches.

8.1.6 CYCLIC DIRECTION OF THE PHASES

In gensets with parallel application, either automatic or standby manual intervention for external production lines, check that the cyclic direction of the phases of the alternator corresponds to the cyclic direction of the phases of the external producer, avoiding reverse engine rotation and other problems.

8.1.7 CHECKING THE STATUS OF THE AIR FILTER

The filters must be unobstructed and without porosities that prevent good air filtration. If damage is present, appropriate maintenance operations must be performed.

8.1.8 CHECKING THE STATUS OF THE RADIATOR AND AFTERCOOLER

Visually check that the air inlet surface of the radiators is free of dirt.

8.1.9 CHECKING THE EARTHING

Check that both the generator, as well as the installation that will be connected to the genset, are earthed (connections, earthing rod...).

8.2 COMMISSION

Perform all the checks described in the preceding sections verifying that the circuit breakers and differential switches are in the OFF position.

It is not recommended to run the generator set for long periods under low load conditions, of less than 30%.

8.3 CHECKS AFTER STARTING THE GENERATOR SET

The following checks must be performed:

- Electrical checks (voltage, current, frequency, rotary field, etc.).
- Mechanical checks (oil pressure, water temperature, absence of noise, etc.).
- Safety checks (emergency stop, oil pressure, water temperature, etc.).

8.4 ELECTRICAL PANEL

The generator set is usually equipped with an electronic protection and control unit, with characteristics that depend on customer requirements, which may include: protection devices (fuses, circuit breakers, differential switches...), measuring instruments (ammeters, voltmeters, frequency meters...), control instruments (fuel level, oil pressure, temperature...), voltage switches and output connection terminals.

Depending on the type of control unit, the operations and operating status of the genset are shown with a set of lights or text. For information on these and other indications and operations, refer to the documentation for the control unit that is supplied with the generator set.

8.5 QUICK GUIDE FOR THE USE OF THE MAIN CONTROL UNITS

8.5.1 CEM, CEA AND CEC CONTROL UNITS



Fig.1
Front view of the display module

The display module has a backlit display and various LEDs for monitoring the status of the control unit. It also has buttons that allow the user to control and program the control unit.

Backlit display with 4 lines of 20 digits.

NOTE:

The display goes into low power mode (backlight off) after 10 minutes without any button being pressed.

Control unit buttons

Control unit operating mode buttons

Control unit command buttons

Display buttons

Status LEDs

ENGINE status LEDs

ALARMS LEDs

CONTACTORS status LEDs

CONTROL UNIT BUTTONS

1. Buttons for control unit operating modes



Automatic mode: The control unit monitors the status of the genset and manages its operation and the programmable inputs.

Manual mode: The control unit is commanded by the user.

Lit LED: Automatic mode active

LED flashing: Automatic mode blocked

LED off: Manual mode active.

2. Control unit command buttons



Engine start button (only in manual mode).
Manages start-up with one touch.
Lit LED: Engine started.



Engine stop button (only in manual mode)
The first press to stop engine while performing a cooling cycle. The second press to stop the engine immediately.
Lit LED: Motor stopping (with or without cooling)



Alarms reset button. Allows acoustic signals to be eliminated and the user to report the alarms.
LED flashing: Alarms pending notification.
Lit LED: Alarms active.



Fuel transfer pump button.
In manual mode, this button activates the fuel transfer pump if the fuel level is below the programmed limit.
Lit LED: Fuel transfer pump active.

3. Display buttons



Confirm (V). Enter the menus and confirm the data entered.

Cancel (X). Leave the menus and cancel the data entered.

Up (+). Advances through the selection of display screens, the maintenance menu selection and increases the programmed values.

Down (-). Go back through the selection on display screens, the selection in maintenance menus and decrease the programming settings.

STATUS LEDS

1. ENGINE status LEDs



Engine started

Lit: Engine started detection
Off: Engine stopped



Preheating

Lit: Engine preheating activated
Off: Engine preheating deactivated



Engine start-up

Lit: Engine start activated
Off: Engine start deactivated

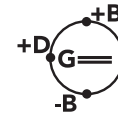

Alternator status
battery charging

Lit: With engine running, voltage in the battery charging alternator is detected.
Off: Engine stopped or started, with no voltage in the battery charging alternator.

2. ALARMS LEDs



Fuel reserve



Battery level



High temperature



Engine start up failure



Overspeed



Low oil pressure

Aux.1

Auxiliary 1 (freely programmable)

Aux.2

Auxiliary 2 (freely programmable)



Lit: Analogue sensor alarm

Flashing: Digital sensor alarm

Off: Without alarm

3. CONTACTORS status LEDs (CEM7 + CEA7, CC2).

These LEDs only appear active when the switching control unit is connected. Start-up option due to Voltage Network Failure (CEM7 + CEA7CC2). The reference symbols M and G which appear on the front of the control unit are only activated when the switching control unit is connected.

	● Network contactor status	Lit: Contactor active
	● Genset contactor status	Flashing: Contactor in the connection/disconnection phase
		Off: Contactor disconnected

8.5.1.1 OPERATING MODES

MANUAL MODE

In manual mode, the control unit is commanded by the user via the front panel of the display module. The user can start and stop the engine by pressing the START and STOP keys respectively.

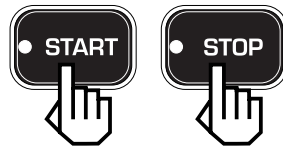

Pressing the START key initiates the engine starting procedure (without deactivating the network contactor CEM7 + CEA7CC2). Pressing the STOP key initiates the engine stopping procedure with cooling; a second press of the STOP key causes the engine to stop immediately without waiting for the cooling time.

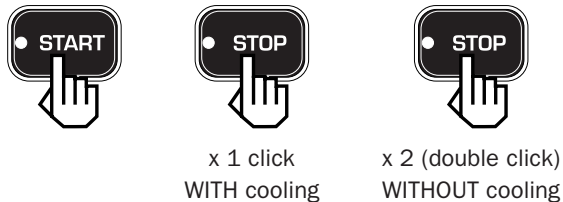

AUTOMATIC MODE

In automatic mode, supervision of the installation is managed by the control unit. Under certain circumstances which can be programmed, the control unit starts the genset to supply the installation.



MODE LOCKING FUNCTION

Pressing the Auto or Man keys for 5 seconds activates the locking of the mode. This status of the control unit is indicated by the flashing of the button for the mode currently active. To deactivate the mode lock and allow normal operation of the control unit, press the key associated to the active mode for 5 seconds.



PRACTICAL EXAMPLE OF A START OPERATION

NOTE

Before starting the start cycle it is advisable to ensure the genset's main circuit breaker is in the off position (OFF).

OPERATION: By pressing the START button the start cycle is initiated and is indicated by the START button's LED switching on. At the same time if the motor has a preheating plug the PR output is activated, with the corresponding LED switching on (Ⓜ), for the programmed time. (1)

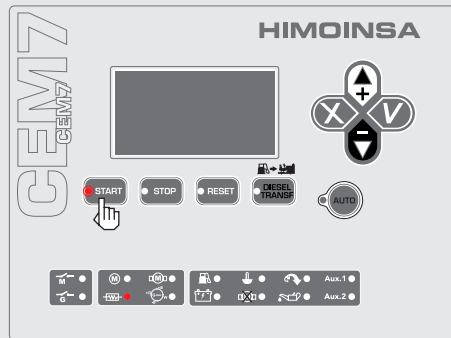

Fig.1

Once this time has elapsed the PR output is deactivated, and the corresponding LED turns off (Ⓜ) and immediately the positive contact of the PC output is activated and 0.5 seconds later the ARR output with the switching on of the LED (Ⓜ), this output remains activated until any engine running condition is detected. (2)

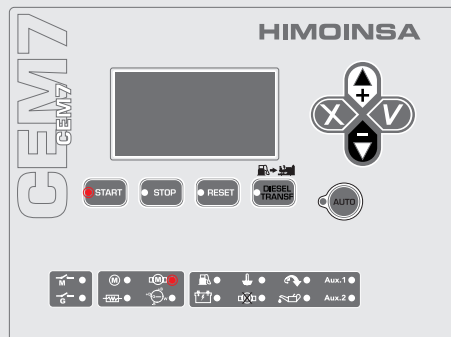

Fig.2

Once it has been detected that the engine is running the LED switches on (Ⓜ), this indicates the end of the start cycle and the START button turns off. (3)

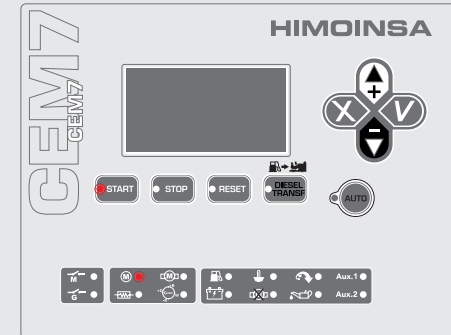

Fig.3

PRACTICAL EXAMPLE OF A STOP OPERATION

NOTE

Before beginning the stop cycle it is advisable to ensure the genset circuit breaker is in the off position (OFF).

The genset can be stopped in various ways:

Manual: Pressing the STOP button once. To perform a stop with a cooling cycle.

Manual: Pressing the STOP button twice. To perform a stop without a cooling cycle.

Put the activation key on the panel to "0". To perform a stop without a cooling cycle.

Automatic: After deactivation of the command enabling the automatic start-up and therefore performing a stop with cooling.

Sequence: We press the STOP button once and begin the stop cycle with engine cooling. This is indicated with the STOP button lighting up. (1)

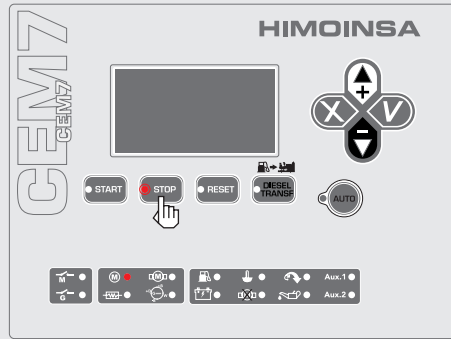

Fig.1

After concluding the cooling time (120 seconds by default), the PC output is disabled or enabled according to the type of engine to carry out the stop, the STOP button and the LED (M) for the started engine switch off (2).

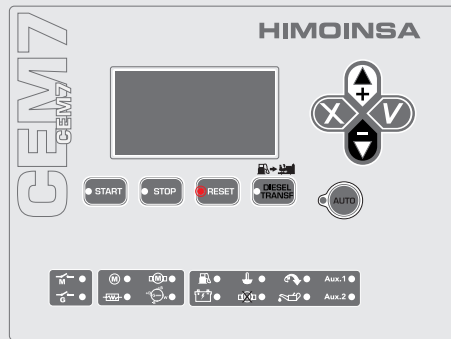

Fig.2

If after a period of time any engine running condition is detected, the control unit shows on the display the STOP FAILURE alarm and the LED of the STOP button remains lit (3).

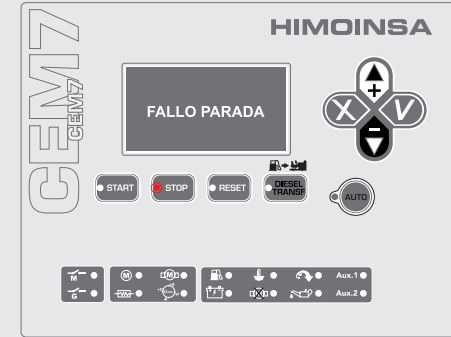

Fig.3

The LED corresponding to the battery charging alternator voltage ($\overset{+B}{\underset{-B}{G}}w$) switches off when the voltage provided by the alternator falls below the programmed voltage threshold (4).

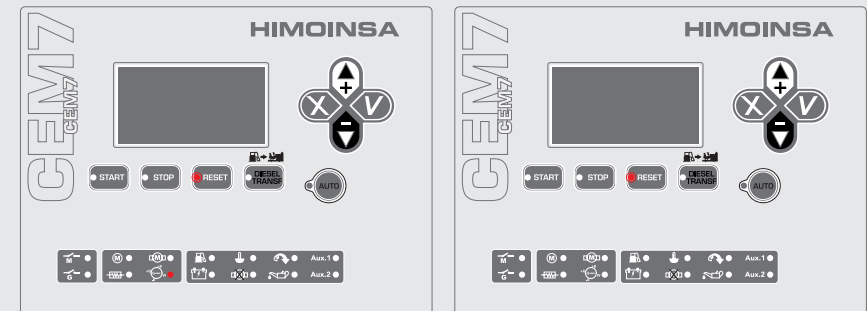

Fig.4

NOTE

An engine status screen is shown on the display, indicating the status of the engine during the stop operation. This sequence is:

- Genset: Stabilized
- Genset: Cooling
- Genset: Stopping
- Genset: Stopped.

8.5.2 M7 CONTROL UNIT

FRONT OF THE M7 CONTROL UNIT



Fig.1

Backlit display with 128x64 pixel resolution.

NOTE

The display goes into low power mode (backlight off) after 10 minutes have passed without any button being pressed.

User interface

Alarms management key

Control unit command keys (start/stop)

Menu keys

Control unit mode key

Status LEDs

Alarm LEDs

CONTROL UNIT BUTTONS

1. Control unit mode selection key



Automatic mode. The start and stop commands on the control unit are managed by programming the control unit.

Manual mode. The control unit is commanded by the user via the command keys.

Mode 0. The control unit is turned off by commanding a generator set stop.

2. Control unit command buttons



Engine start button (only in manual mode)
Manages start-up with one touch.



Engine stop button (only in manual mode)
The first press to stop engine while performing a cooling cycle.
The second press to stop the engine immediately.

3. Display buttons



Confirm. Enters the menus and confirms the data entered.
Notify. Deletes non-active alarms from the alarms display page.



Cancel. Goes back through menus and cancels data entered.
Alarms. Go to the alarms display page



Up. Advances through the selection of display screens, the maintenance menu selection and increases the programmed values.



Down. Goes back through the selection of display screens, the maintenance menu selection and decreases the programmed values.

4. Status LEDs Alarms LEDs



Control unit
status

Lit: Alarm active

Flashing: Alarm inactive pending notification

Off: No alarm

8.5.2.1 OPERATING MODES

MANUAL MODE

In manual mode, the control unit is commanded by the user via the front panel of the display module. The user can start and stop the engine by pressing the START and STOP keys respectively.



Pressing the START key initiates the engine start-up operation. Pressing the STOP key initiates the engine stopping procedure with cooling; a second press of the STOP key causes the engine to stop immediately without waiting for the cooling time.



x 1 click
WITH cooling

x 2 (double click)
WITHOUT cooling

NOTE:

In manual mode, the control unit's protection devices remain active, being able to produce alarms that cause the engine to stop. In manual mode, the control unit does not take into consideration the start conditions (programmed, by external signal) that can be programmed.

AUTOMATIC MODE

In automatic mode, the monitoring system is managed by the control unit enabling the start-up of the genset through voltage free contact (LT).

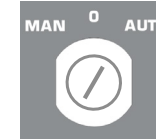



PRACTICAL EXAMPLE OF A START OPERATION

NOTE

Before starting the start cycle it is advisable to ensure the genset's main circuit breaker is in the off position (OFF).

 **PREHEATING:** Pressing the START button initiates the start-up cycle. At the same time if the engine has a preheating plug the PR output is activated for the time set (Times table, parameter 402).

 **STARTING:** Once the set time has elapsed the PR output is immediately deactivated and the positive contact PC output is activated and 0.5 seconds after the ARR output until a started engine condition is detected for a maximum set time (Times table, parameter 403). If the maximum set start-up time is exceeded (Times table, parameter 403) without detecting any engine started condition, the control unit waits for a period of time (Times table, parameter 401) before re-initiating the engine start-up. This process is repeated for a set maximum number of times (Thresholds table, parameter 301).

 ^{KG}**STARTED:** Once the started engine is detected a set waiting time (Times table, parameter 405) begins for the engine to stabilize before activating the genset contactor that provides the electric power.

 ^{KG}**STABILIZED:** After the stabilization time has elapsed, the control unit completes the generator set start-up process.

To interrupt the start cycle just press the STOP button.

NOTE

For more information refer to the corresponding manual.

PRACTICAL EXAMPLE OF A STOP OPERATION

NOTE

Before beginning the stop cycle it is advisable to ensure the genset circuit breaker is in the off position (OFF).

The genset can be stopped in various ways:

Manual: Pressing the STOP button once. To perform a stop with a cooling cycle.

Manual: Pressing the STOP button twice. To perform a stop without a cooling cycle.

Put the activation key on the panel to "0". To perform a stop without a cooling cycle.

Automatic: After deactivation of the command enabling the automatic start-up and therefore performing a stop with cooling.

COOLING: Press the STOP button once, the genset contactor is deactivated and the stop cycle with engine cooling begins.

STOP: After the cooling time has ended (Times table, parameter 407), the PC output is disabled or enabled according to the type of engine to perform the stop (Settings table, parameter 106).

STOPPED: The M7 control unit ends the engine stop process once all the engine started conditions are no longer detected. If after a period of time (Alarms table, parameter 1071) any engine started conditions are still detected, the STOP FAILURE alarm will be activated.

8.5.3 M7X CONTROL PANEL

The M7x control unit has a backlit display with a resolution of 128x64 and several LEDs to view generator set status. It also has buttons that allow the user to control and program the control unit.

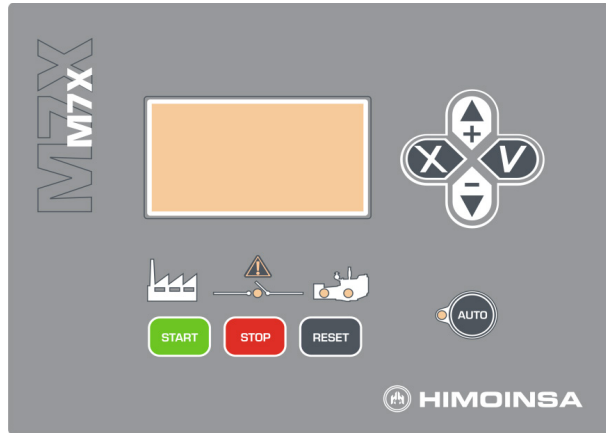

Fig.1
Front of the M7x control unit

1. Backlit display with 128x64 pixel resolution

NOTE:

The display goes into low power mode (backlight off) after 10 minutes have passed without any button being pressed.

2. User interface

- Alarms management key
- Control unit command keys (start/stop)
- Menu keys
- Control unit mode key

3. Status LEDs

- Alarm LED
- Engine status LED
- Generated electric signal status LED
- Genset contactor status LED

CONTROL UNIT BUTTONS

CONTROL UNIT OPERATING MODE BUTTONS

Control unit modes:

- **Automatic mode.** The control unit monitors the status of the genset and manages its operation and the programmable inputs.
- **Manual mode.** The control unit is commanded by the user.



Lit LED: Automatic mode active

Flashing LED: Automatic mode locked

LED off: Manual mode active

Control unit command buttons



Engine start-up button (only in manual mode)
Manages start-up with one touch.



Engine stop button (only in manual mode)
The first press stops the engine following a cooling cycle.
The second press stops the engine immediately.



ALARMS RESET button
Allows notification of the alarm by the user.

Display buttons

Confirm (V). Enters the menus and confirms the data entered.

Cancel (X). Leaves the menus and cancels the data entered.



Up (+). Advances through the selection on display screens, the selection in maintenance menus and increases the programmed values.

Down (-). Goes back through the selection on display screens, the selection in maintenance menus and decreases the programmed values.

STATUS LEDS

ALARMS LEDs

	Control unit status	Lit: Alarm active Flashing: Alarm inactive pending notification Off: No alarm
---	---------------------	--



NOTE

For more details, see the Alarms section.

CONTACTORS status LEDs

	Genset contactor status	Lit: Contactor active Off: Contactor disconnected
---	-------------------------	--

Generator status LEDs.

	Engine status	Lit: Active status without errors
	Status of the generator set's AC electric signal	Flashing: Status with errors Off: Inactive status

PASSWORDS

The M7x control unit has 2 levels of 4-digit passwords to protect against unauthorized access. The different levels of access are as follows:

- **User** (default password: 1111). User level access allows the operator to access the main menu of the M7x control unit.
- **Maintenance** (default password: 1911). Maintenance level access allows the operator to access the Parameters programming option from the main menu.

The M7x control unit's passwords are customizable by the user from the main menu. A user can configure both passwords for their access level and lower-level passwords.

NOTE

To enter a password, see Appendix II: Password entry

OPERATING MODES

MANUAL MODE

In manual mode, the control unit is commanded by the user via the front panel of the visualization module. The user can start and stop the engine by pressing the START and STOP keys respectively.

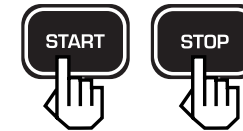

Pressing the START key initiates the engine starting procedure (without deactivating the network contactor). Pressing the STOP key initiates the engine stop operation with cooling; a second press of the STOP key causes the engine to stop immediately without waiting for the cooling time.



x 1 click
WITH cooling

x 2 (double click)
WITHOUT cooling

NOTE

In manual mode, the control unit's protection devices remain active, being able to produce alarms that cause the engine to stop. In manual mode, the control unit does not take into consideration the start-up conditions (programmed, by external signal) that can be programmed.

AUTOMATIC MODE

In automatic mode  supervision of the installation is managed by the control unit. Under certain circumstances which can be programmed, the control unit starts the genset to supply the installation.

Programmable conditions for genset start-up and activation of the genset contactor include:

- External start-up
- Forced operation signal (Configuration table, parameter 110 and 120 or 121)
- Programmed start time (only M7xR control unit)

Locking OPERATION MODE

Pressing the AUTO button for 10 seconds activates the lock mode. This status of the control unit is indicated by the flashing of the button for the mode currently active. To deactivate the mode lock and allow normal operation of the control unit, press the button associated with the active mode for 10 seconds.



PRACTICAL EXAMPLE OF A START-UP OPERATION

NOTE:

Before starting the start-up cycle it is advisable to ensure the genset's main circuit breaker is in the off position (OFF).



PREHEATING: Pressing the START button initiates the start-up cycle. At the same time, if the engine has a preheating plug, the PR output is activated for the time set (Times table - parameter 402).



START-UP: Once the set time has elapsed the PR output is immediately deactivated and the positive contact PC output is activated and 0.5 seconds after the ARR output until a started engine condition is detected for a maximum set time (Times table - parameter 403). If the maximum set start-up time is exceeded (Times table - parameter 403) without detecting any engine started condition, the control unit waits for a period of time (Times table - parameter 401) before re-initiating the engine start-up. This process is repeated for a set maximum number of times (Thresholds table - parameter 301).



STARTED: Once the started engine is detected, a set waiting time (Times table - parameter 405) begins for the engine to stabilize before activating the genset contactor that provides the electric power.



STABILIZED: After the stabilization time has elapsed, the control unit completes the generator set start-up process.

To interrupt the start-up cycle just press the STOP button.

NOTE

The start an automatic system using a timer, external signal, etc. is carried out following the same process as when starting manually.

PRACTICAL EXAMPLE OF A STOP OPERATION

NOTE

Before beginning the stopping cycle, it is advisable to ensure the genset circuit breaker is in the off position (OFF).

The genset can be stopped in various ways:

1. Manual: Pressing the STOP button once. To perform a stop with a cooling cycle.

2. Manual: Pressing the STOP button twice. To perform a stop without a cooling cycle.

3. Turning the panel's **activation selector** to the "0" position. To perform a stop without a cooling cycle.

4. Automatic: After disabling the start-up condition producing a cooling stop.

COOLING: Press the STOP button once, the genset contactor is deactivated and the shutdown cycle with engine cooling begins.

STOP: After the cooling time has ended (Times table - parameter 407), the PC output is disabled or enabled according to the type of engine to perform the stop (Configuration table - parameter 106).

STOPPED: The M7x control unit ends the engine stop process once all the engine started conditions are no longer detected. If after a period of time (Alarms table - parameter 1071) any engine started conditions are still detected, the **STOP FAILURE** alarm will be activated.

8.5.4 DEEPSEA CONTROL UNIT

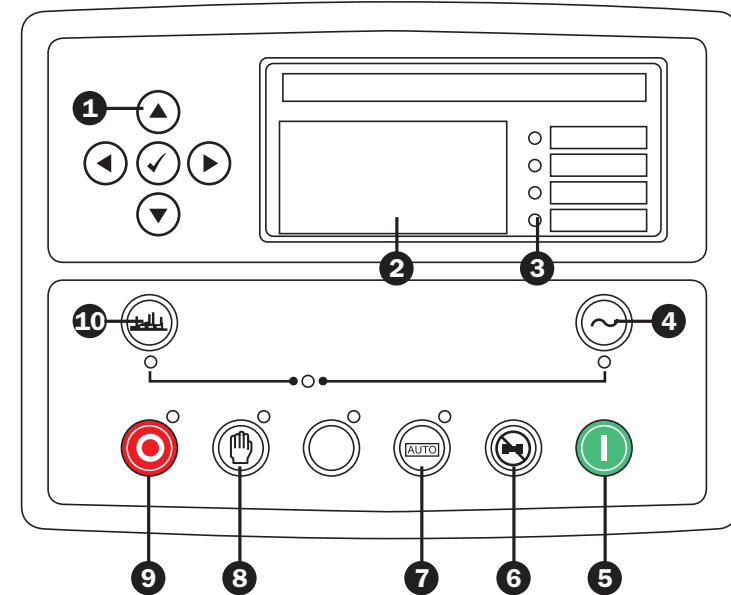

FRONT OF THE DISPLAY MODULE



CONTROL UNIT BUTTONS

1. Navigation buttons	6. Cancel Audible Alarm button
2. General Display	7. Automatic mode button
3. Programmable LEDs	8. Manual mode button
4. Switch open button	9. "Stop" button
5. "Start" button	10. Switch close button

ENGINE START-UP

5. First Select Manual Mode 
6. Press to Start-up the Engine 

STOPPING THE ENGINE

Press to Stop the Engine 

NOTE

For more information refer to the corresponding manual.

9. MAINTENANCE

A suitable maintenance and revision programme, performed only by qualified technicians, is essential to maximize the reliability of the engine, minimizing repairs and reducing long-term costs.

To carry out an effective maintenance programme, it is recommended that any data obtained during operation be collected, using the timer operation of the generator set to keep accurate records of all the services performed. This record will also be important for warranty issues.

For specific maintenance plans related to the Generator set acquired, refer to the appropriate documentation for the engines, alternators and certain accessories. These plans vary according to:

- Hours of operation
- Fuel quality
- Machine location
- Type of load supplied
- Environmental conditions

Therefore, once the genset has been received and taking into account the above elements, these maintenance plans should be studied to determine the maintenance intervals which need to be carried out.

It is important to perform continuous cleaning of the generator set, also avoiding the accumulation of fluids on both the internal and external surfaces as well as the acoustic materials installed. To perform the cleaning do not use flammable solvents, it is recommended that aqueous liquids for industrial cleaning are used.

It is recommended that the genset be started at least once a month if it is not used over long periods, allowing its status to be checked.

IMPORTANT

Before any operation, stop the generator and wait until it cools down for at least 15 minutes.

10. WARRANTY CONDITIONS

10.1 LIMITED WARRANTY PERIODS

PROFESSIONAL USE (commercial):

Generator Sets, Prime Power Applications, Rental, Continuous (whichever period expires first)

- 4,000 working hours
- 24 months from start-up
- 30 months after leaving the factory

Generator Sets at 3000 rpm Prime Power Applications (whichever period expires first)

- 500 working hours
- 12 months from start-up
- 18 months after leaving the factory

DOMESTIC USE (private):

Generator Sets Stand-by Applications, Limited Continuous (whichever period expires first)

- 1000 working hours (500 hours/year)
- 24 months from start-up
- 30 months after leaving the factory

Generator Sets at 3000 rpm Stand-by Applications (whichever period expires first)

- 500 working hours
- 24 months from start-up
- 30 months after leaving the factory

The coverage of this warranty is ONLY applicable to the end user of the equipment recognized by HimoinSA. In the case of generator sets, it is only applicable to those generator sets that operate together with a manual or automated control panel manufactured and/or installed by HIMOINSA.

10.2 COMPANY RESPONSIBILITIES

- In those countries where HIMOINSA has an authorized technical assistance network (information available at www.himoinsa.com) the warranty consists of the replacement or repair of the damaged parts once it has been ascertained that the damage is due to defective material at origin or during the manufacturing or the assembly process. The warranty therefore covers both the replaced parts as well as the manpower used during normal working hours. The customer shall be charged with shipping costs to the premises of the authorized distributor, where the repairs shall be carried out.
- The warranty for the rest of the world consists of free supply on premises San Javier (Murcia, Spain), of the non-usable parts due to defective material at origin, manufacturing or/and assembly. If the equipment is sent to our premises, all necessary repair tasks will be carried out free of charge.
- In this case, the shipping costs, both sending and return, will be chargeable to the customer.
- The warranty will only be given after the technical study of the defective parts. Any part sent or service carried out before the acceptance of the warranty will be billed. All replaced parts have to be returned to Himoinsa and will become of its property.
- In case of defects in the engine or the alternator, HIMOINSA informs that the assistance covered by the warranty will be provided by the official technical services of the manufacturer of the alternator or the engine, who will determine the scope of the warranty.
- The defect shall appear during the normal use of the product and within the warranty period. The company will supply the necessary spare parts for the repair as soon as possible but shall not be deemed responsible for any losses for not having the equipment during this period.
- All claims made based on this warranty, must be processed through your authorized seller or area distributor, who will process the claim and the scope of the warranty.
- This warranty does not cover failures or defects that are the consequence of normal use or wear, inappropriate use (including overload and overvoltage), negligence, accidental damages, non-authorized modifications; lack of maintenance or inappropriate maintenance or connections, (inappropriate storage, transportation or installation); any kind of use of the equipment over and above the capacity and limits established by the manufacturer or under conditions that differ from those recommended; failures caused after another failure or defect had or should have been detected; damage

to batteries, lamps and fuses; damages due to the use of parts not supplied or manufactured by the manufacturer. The Warranty also does not cover the rental costs of substitution equipments during repair period nor connection costs and/or connection works of the product with other equipments of the customer.

- The repaired or replaced parts have a (6) six-month warranty, this will not modify the warranty of the other elements.
- Equipment or components not manufactured by the company. The company will provide a warranty equal to the one supplier, and limited to the responsibility offered by the company for its equipment.
- All claims to do with the fuel injection system or parts of it, will be referred by HIMOINSA to the manufacturer of the injection system, or to its authorized agent. The manufacturer or authorized agent's report ON THE FAILURE will be binding for both parties: Himoinsa and purchaser.

10.3 USER RESPONSIBILITIES

The user is responsible for:

- Installing and operating the product in accordance with the operation and instruction manual provided, and in its case with the assistance of qualified technical personnel and in accordance with the current regulations.
- Carrying out a proper maintenance of the equipment (including the use of appropriate fuel, oil, antifreeze, and lubricant), as well as to replace of the parts and components due to the normal use of the equipment.
- Returning the warranty register form properly filled in within 10 days after the commissioning of the product, or a month after the date of the sale, whichever is first.
- Sending written notification to the company or to the authorized technical assistance service in his or her country, of the failures of the material and the justification thereof, within seven days after the failure were to appear and in any case before the expiration of the warranty. Otherwise, the purchaser may lose his or her warranty rights.
- If the repair of the defect requires the participation of other equipment not manufactured by HIMOINSA, the purchaser will be solely responsible for the resultant work and costs. Furthermore, he or she must also provide full access to the products that were manufactured by HIMOINSA S.L.

- Accepting the technical report about the existence or non-existence of defects in the material or the assembly.
- The manpower costs, except for those stated in the section “COMPANY RESPONSIBILITIES”, including those ones derived from the assembly and disassembly of the equipment.
- The costs and risks from transportation or shipping of the equipment, and any other costs associated with the replacement of the components.
- Any cost that may exceed the purchasing price of the product.
- Any other cost, including transport and trips, accommodation, taxes and fees, communication expenses, extra hours among others; except for those stated in section "Company responsibilities".
- Payment of the total price of the machine, spare parts and related services related with the product under warranty.
- The attendance of sales or technical personnel at commissioning or performance demonstrations of the equipment will not mean that this warranty may be extended to the installation or the assembly. Performance is expressly excluded from this warranty. Nor does it imply acceptance or understanding of the correct technical installation, assembly or connection of the machine, carried out by the purchaser or by a third party unrelated to Himoinsa, nor of the dimensioning of the purchased equipment with regard to the real power supply needs of the purchaser.

The present warranty will not be applicable to the following cases:

- When the documentation (warranty, purchasing invoice, maintenance and use manual) may have been altered in any way or may be illegible.
- If the model and serial number of the generating set have been altered, erased, removed or are illegible.

HIMOINSA shall not be deemed contractually or extra contractually responsible for any material or immaterial, direct nor indirect damages; consecutive or non-consecutive to the damage on the material covered by the warranty, such as operating losses, expenses and costs due to not having the product, neither for damages to third parties or to other equipment or products.

This Warranty does not limit any other rights that as a consumer, the purchaser may have according to the current legislation. This warranty replaces any other express or implied warranty, including, without limitation any merchantability warranty of the equipment or its suitability for a particular purpose. All claims not covered by the above stipulations will not be accepted by the company.

HIMOINSA informs the user that he or she is obliged to follow the Maintenance and Use Manual and to keep it together with the rest of the technical documentation of the equipment in observance with safety in the workplace regulations. And also that they are advised to install specific protections that prevent overvoltage and overload from the main electrical line, and to protect the equipment by seeking the advice of an authorized installer.

11. APPENDIX I: EQUIVALENCE OF THE DIFFERENT UNITS WITH SI UNITS

Length (m)

1 Å	$1 \cdot 10^{-10}$	m
1 μ	$1 \cdot 10^{-6}$	m
1 in	0.0254	m
1 ft = 12 in	0.3048	m
1 yd = 3 ft = 36 in	0.9144	m
1 mi (mile)	$1.6093 \cdot 10^3$	m
1 M (nautical mile)	$1.8533 \cdot 10^3$	m

Angle (rad)

1 °	$\pi/180$	rad
1 ′	$\pi/(1.08 \cdot 10^5)$	rad
1 ″	$\pi/(6.48 \cdot 10^6)$	rad
1 r (rev.)	2π	rad

Speed (m/s)

1 km/h	0.2778	m/s
1 ft/h	$8.4667 \cdot 10^{-5}$	m/s
1 ft/min	$5.08 \cdot 10^{-3}$	m/s
1 ft/s	0.3048	m/s
1 mile/h	0.44704	m/s

Acceleration (m/s²)

1 ft/s ²	0.3048	m/s ²
1 g	9.8106	m/s ²

Pressure (Pa)

1 bar	$1 \cdot 10^5$	Pa
1 kg/cm ²	$9.8066 \cdot 10^4$	Pa
1 atm	$1.0133 \cdot 10^4$	Pa
1 kp/cm ²	$9.8067 \cdot 10^4$	Pa
1 torr	133.32	Pa
1 mmHg	133.32	Pa
1 mmH ₂ O (mmca)	$9.8066 \cdot 10^3$	Pa
1 dyn/cm ²	$1 \cdot 10^{-1}$	Pa
1 inHg	$3.3866 \cdot 10^3$	Pa
1 PSI (lbf/in ²)	$6.8948 \cdot 10^3$	Pa
1 lb/ft ²	0.4788	Pa

Surface (m²)

1 in ²	6.4516·10 ⁻⁵	m ²
1 ft ²	0.0929	m ²
1 yd ²	0.8361	m ²
1 acre	4.0469·10 ³	m ²
1 mi ² (mile)	2.59·10 ⁶	m ²

Mass flow rate (kg/s)

1 m/s	1·10 ⁻³	kg/s
1 lb/h	1.26·10 ⁻⁴	kg/s
1 ton/h (short)	0.252	kg/s
1 ton/h (long)	0.2822	kg/s

Volumetric flow rate (m³/s)

1 l/s	1·10 ⁻³	m ³ /s
1 ft ³ /s	0.02832	m ³ /s
1 yd ³ /s	0.7645	m ³ /s
1 USgal/h	1.0515·10 ⁻⁶	m ³ /s
1 UKgal/h	1.2628·10 ⁻⁶	m ³ /s

Temperature (K)

T °C	T + 273.15	K
T °F	5/9 (T-32)+273.15	K
T °R	5/9	K

Volume (m³)

1 l	1·10 ⁻³	m ³
1 in ³	1.6387·10 ⁻⁵	m ³
1 ft ³	0.02832	m ³
1 yd ³	0.7645	m ³
1 US gal	3.7853·10 ⁻³	m ³
1 UK gal	3.546·10 ⁻³	m ³

Mass (kg)

1 grain	6.48·10 ⁻⁵	Kg
1 lb	0.4536	Kg
1 ton (short)	907.18	Kg
1 ton (long)	1.016·10 ³	Kg
1 dram	1.77·10 ⁻³	Kg
1 oz	0.02835	Kg

Force (N)

1 kp	9.8067	N
1 dyn	1·10 ⁻⁵	N
1 lbf	4.4482	N

Power (W)

1 J/s	1	W
1 kcal/s	4187	W
1 BTU/h	0.2928	W
1 cv	735.5	W
1 ft lbf/min	0.0226	W
1 kgf·m/s	9.807	W
1 erg/s	1·10 ⁻⁷	W
1 hp	745.7	W

Energy, heat, work (J)

1 Nm	1	J
1 Ws	1	J
1 dyncm	1·10 ⁻⁷	J
1 erg	1·10 ⁻⁷	J
1 cal	4.1868	J
1 kWh	3.6·10 ⁶	J
1 hp h	2.6845·10 ⁶	J
1 cv h	2.65·10 ⁶	J
1 BTU	1.0551·10 ³	J
1 therm	1.0551·10 ⁸	J
1 Therm	4.1868·10 ⁶	J
1 PSI (lbf/in ²)	6.8948·10 ³	J
1 ft·lbf	1.3558	J
1 kgf·m	9.807	J
1 electron-volt	1.6·10 ⁻¹⁹	J



FACTORIES

SPAIN • FRANCE • INDIA • CHINA • U.S.A. • BRAZIL • ARGENTINA

SUBSIDIARIES

PORTUGAL | SINGAPORE | POLAND | UAE | PANAMA
DOMINICAN REP. | GERMANY | ARGENTINA | ANGOLA |
UNITED KINGDOM | SOUTH AFRICA | MOROCCO | AUSTRALIA

HEADQUARTERS

Ctra. Murcia - San Javier, km 23.6
30730 SAN JAVIER (Murcia) SPAIN
Tel.: +34 968 19 11 28 | +34 902 19 11 28
Fax: +34 968 19 12 17 | Fax - Exports: +34 968 33 43 03

www.himoinsa.com

HimoinSA reserves the right to change any feature without prior notice. The illustrations may include optional equipment and/or accessories. Not contractual images. The technical indications described in this manual correspond to the information available at the moment of printing.
HIMOINSA® - 2020 © All rights reserved.

HIMOINSA
A **YANMAR** COMPANY